



## IOT BASED PREPAID ENERGY METER WITH DATA ACQUISITION USING GSM AND NODE MCU

Yandluri Mamatha<sup>1</sup>, Dr V Madhusudana Reddy<sup>2</sup>

<sup>1</sup>M.Tech Scholar, Department of EEE PBR VITS, Kavali

<sup>2</sup> Professor, Department of EEE PBR VITS, Kavali.

**Abstract**—The Internet of Things (IoTs) is important in the energy industry since it creates a smart metering and monitoring system. High attention to detail focuses on combining energy meter and control mechanisms, which necessitate smart equipment control, bidirectional communication, and networking as well as user interaction. Energy meters in India are mechanical and postpaid. The primary disadvantage of this method is that a person must travel from street to street, checking each house's energy meter and issuing charges. The payment was made, according to that reading. Even when bills are paid on time, problems such as over-billing or provider warnings are prevalent. To address this issue, we proposed an IoT-based prepaid power recharge unit that will integrate with standard household energy meters and be capable of counting down energy use and switching off the main power supply once the energy usage countdown reaches zero, as well as an IoT-based data collection system. The recharge information and energy consumption from the recharge station are recorded in a Data Acquisition server linked to the energy meters in order to manage the main power supply and monitor power consumption in real-time.

**Index Terms**— IOT, energy meter, prepaid, data acquisition

### I. INTRODUCTION

ENERGY is an essential factor for a country's economic development, as well as for increasing people's lifestyles on the globe. As the nation's population grew, so does the energy requirements. A smart device is an intelligent power meter that detects a public's energy use and sends additional information to the utility via a multiple effective communication [1,2]. The conventional manual meter reading method proved unsuitable for long-term operations since it consumes a lot of human and material resources. It causes extra issues when manually calculating readings and invoicing. The number of people who use energy is rapidly growing these days. It became difficult to manage and sustain electricity in response to the increasing demands [3]. The integration of automated systems via communication systems over a web has now become a demand. With the rise of technology, research on communication systems and home automation has gained significance and desirability [4]. An Intelligent Energy Meter is a device that detects energy usage at predetermined intervals and transmits that data to the utility for monitoring, administration, and invoicing [5]. The customer has a variety of issues as a result of post-paid connections. Prepaid electricity connections are frequently

proposed as a potential solution to this problem. In this prepaid electricity meter circuit, consumers will need to replenish the amount of energy they need to consume [6]. To enable this prepaid system to function, residential energy meters must be outfitted with a module capable of identifying the amount recharged by the user and tallying the amount recharged to zero based on power usage. When the meter count reaches zero, the main supply is immediately shut off, and it can only be turned back on after the next recharge.

The Arduino, a GSM board, and a node MCU were used to demonstrate this idea. Using an internet gateway, we can restore our energy balance. If the balance is low or zero, the power supply link to the dwelling is instantly disconnected. This device may also send energy consumption notifications from the meter to the substation at regular intervals through the node MCU module, as well as alerting users to low balance, cutoff, and other problems. The mechanism is set up such that at the end of every month, the gadget generates the unit cost and sends it to the smartphone application along with the billing. The web - based application that will be synced to same server as the energy device.

### II. MOTIVATION AND EXISTING WORK

Many nations have implemented the notion of prepaid admission. This concept is based on the premise of "pay first,



Fig. 1 Existing System

use later." The notion appeals to the consumer since there is no fear of disconnection and reconnection for any reason. Under the present invoicing approach, the Electricity Board is unable to keep track of user power usage (postpaid). Even if bills are paid on time, the client may encounter difficulties such as getting late bills for payments already made, as well as insufficient electricity supply and quality. Energy metering or smart meters are electronic device that can detect and show energy consumption in the form of readings. Traditional meters have been widely used since the late 1800s. These electrical metering may be configured to facilitate information interchange among electronic devices in an electricity network and may be engaged in both the manufacture and supply of power [7]. To calculate energy usage, most conventional electric meters employ a revolving disk composed of copper or aluminum connected to a clock mechanism through a gear mechanism and a display. Because energy is measured using a mechanical construction, conventional meters are also known as electromechanical meters [8]. Electricity meters are now digitally operated, although they still have significant restrictions. Many nations, particularly those in Europe, have begun extensive implementation of digital, smart energy meters [9].

Energy distribution and maintenance are the responsibility of the local state electrical board. The amount of KWH consumed over the course of a month is multiplied to calculate a user's power usage (Fig. 1). This reading is kept locally on the meter. This reading is taken manually by a power board person who visits door to door. This data is then sent to the head electrical board for review, and an evaluation bill is generated based on the monthly measurements. Customers then pay their costs using their selected mode of payment. This procedure takes a long time and a lot of human labor, and the cost is totally reliant on the readings of the employees. So, whatever reading a staff records for a client, the consumer

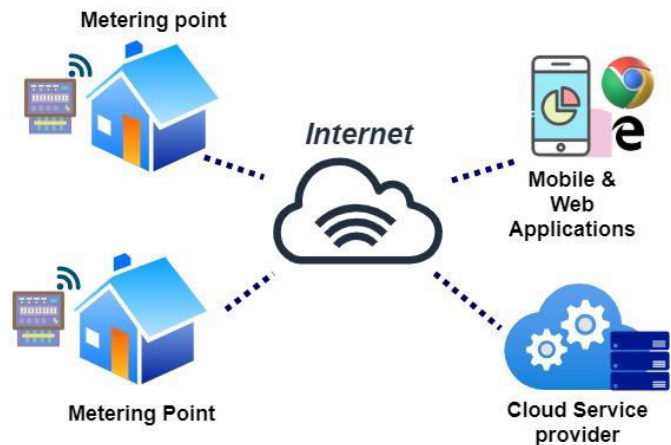

Fig. 2 Proposed Frame Work

must pay for it, and because post-paid power payment is used, many consumers use electricity inefficiently and sometimes do not pay for months.

### III. PROPOSED SYSTEM

The suggested solution is an IoT-enabled prepaid energy meter. This suggested meter assists in the tracking of energy consumption and the automatic computation of bills using a controller. This data is saved on the server and sent to the customer via the GSM module application. The node MCU module is used to send the data to the server (Fig. 2). Customers may utilize the built-in user interface to keep track of their power use.

### IV. IMPLEMENTATION

#### A. Hardware Requirements:

- Arduino Mega controller board
- Liquid crystal display
- GSM Modem
- Node MCU
- Energy Meter
- LED
- 5v Relay
- Lamp

#### B. Software Requirements

- Arduino software
- Embedded c programming
- HTML
- PHP

### C. Block Diagram

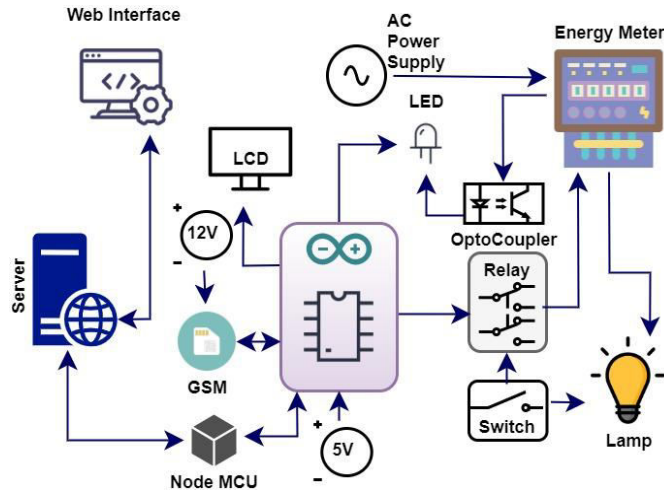

Fig. 3 Block diagram of proposed system

## V. COMPONENT DESCRIPTION

### A. Arduino Mega:

This board has 54 digital I/O pins (14 of which may be used as PWM outputs), 16 analog inputs, 4 UARTs (hardware serial ports), a 16 MHz crystal oscillator, a USB connection, a power connector, an ICSP header, and a reset button. It comes with everything you need to get started with the microcontroller, such as a USB cable to connect it to a computer and an AC-to-DC converter or battery to power it.

### B. LCD Display:

- 16\*2 LCD with green colour Backlight
- works on 5V DC supply
- 2 Rows and 16 Characters Per Row
- Displays two lines of 16 characters High contrast and a wide viewing angle

### C. GSM MODEM:

GSM is an abbreviation for a mobile communication modem. It is mostly used for data transfer in mobile communication all over the world. A GSM modem is a type of modem that, like our cellphone, accepts a SIM card and operates by registering with a mobile carrier. GSM modems work in full duplex mode for sending and receiving SMS. It is an open cellular technology that allows mobile phone and data services to be communicated over the 850MHz, 900MHz, 1800MHz, and 1900MHz frequency bands.

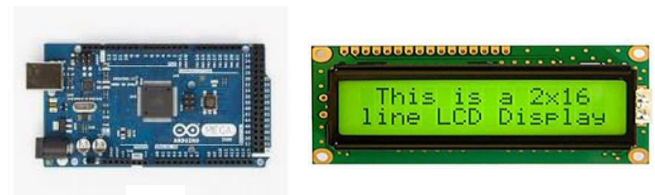

a.

b.

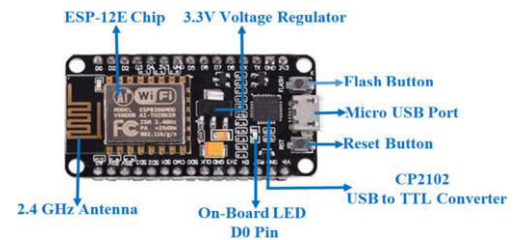

c.



d.



e.



f.

Fig. 4 a) Arduino Mega, b) LCD, c) Node MCU, d) GSM Module, e) Energy Meter and f) Relay

### D. Node MCU Module:

NodeMCU is an open-source Lua-based Internet of Things (IoT) firmware and development board. It includes software for Espressif Systems' ESP8266 Wi-Fi SoC as well as hardware for the ESP12 board. Because it is simple to use, the Arduino IDE can easily program the NodeMCU development Board. The Arduino IDE will just take 5-10 minutes to program the Node MCU. We only need the Arduino IDE, a USB cable, and the NodeMCU board.

### E. Energy Meter:

When a load is applied to this meter, a pulse LED blinks. If this LED blinks 3200 times, 1 KWH has been used. The metre constant is used to determine the accuracy of a metre during manufacture based on its class.

### F. Relay Module:

A relay is a switch that is activated by electricity. The unit consists of input terminals for single or multiple controllers, as well as a set of functional touch terminals. You can discover any number of connections of any type on the switch, including create contacts, divide contacts, and combinations of the two.

## VI. RESULTS AND DISCUSSIONS

### A. Algorithm:

- In order to use this technique, users must first replenish the amount of power they intend to consume by SMS.
- The recharged quantity and units are displayed on the LCD in the Consumer's system.
- The electricity meter has a mechanism that recognizes the amount refilled by the user and then counts down from the recharged amount to zero depending on the electricity usage and sends the information to a server.
- When the meter reading approaches 0, the connection to the main supply is automatically removed and will be restarted when the next recharge is completed.

### B. Calculation of Pulses and Units:

Before we begin our calculations, we must first establish the pulse frequency of the energy meter. The first is 1600 imp/kwh, while the second is 3200 imp/kwh. In this example, we're going to use a 3200 imp/kwh pulse rate energy meter. To begin, we must calculate the Pulses for 100 watts, which is the number of times the Pulse LED would blink in a minute for a 100 watt load.

$$Pulse = \frac{(Pulse\_rate * watt * time)}{(1000 * 3600)} \dots \dots \dots (1)$$

The following may be computed using the equation. 1 using a 3200 imp/kwh rate and a 60-second pulse bulb for a 100-watt bulb:

$$Pulses = \frac{3200 * 100 * 60}{1000 * 3600}$$

$$Pulses = \sim 5.33 \text{ pulse / minute}$$

The single pulse Power factor is now computed as follows:

$$Power\ Factor = \frac{watt}{(hour * Pulse)} = \frac{100}{60 * 5.33} = 0.3125 \frac{watt}{one\ pulse}$$

$$Units = \frac{Power\ Factor * Total\ pulse}{1000}$$

$$No\ of\ pulses\ in\ one\ hour = 5.33 * 60 = 320$$

$$\therefore Units = \frac{0.3125 * 320}{1000} = \frac{0.1}{hour}$$

Let's say a 100-watt bulb is used for a day's worth of



a.

Received #60\*

Energy Meter Balance Alert:  
Your energy meter has been recharged Rs: 60

Energy Meter Balance Alert:  
Low Balance

Please recharge your energy meter soon.  
Thank you

Energy Meter Balance Alert:  
Light cut due to low Balance  
Please recharge your energy meter soon.  
Thank you

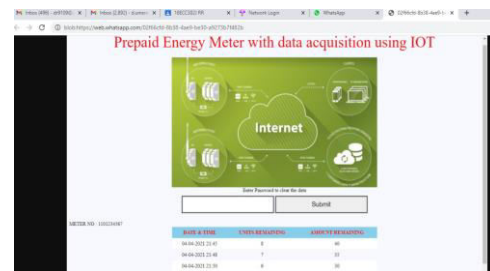
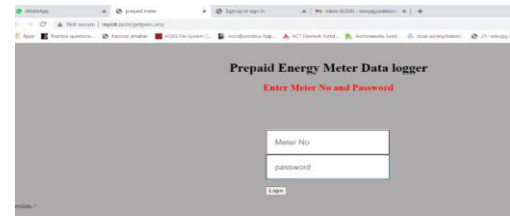

Fig. 5 a) The proposed prepaid energy meter system, b) showing SMS received when recharged is done, c) showing SMS alert received from prepaid meter when balance is low, d) showing connection cut SMS alert received from prepaid energy meter, e) Logging in to Data Acquisition Page and f) showing Data Acquisition Page



lighting then,

$$\text{No of Units} = 0.1 * 24 = 2.4 \text{ Units}$$

And let us assume unit rate at our area is 5 rupees per unit then the amount that we have to pay for 2.4 Units is,

$$\text{Rs: Rupees} = 2.4 * 5 = 12 \text{ rupees}$$

### C. Results

The diagram depicts an overview of the proposed project's hardware, which includes the Arduino mega, GSM modem, LCD display, Node MCU, relay, and variable load. When the load is first connected to the prepaid energy meter, it consumes energy. The balance decreases as the load consumes. When the user's balance reaches a particular amount, he or she receives an SMS notification. The user will receive a confirmation message when the power board has completed the recharge procedure, which will also indicate the current balance. The user will benefit from the notification messages, and the user will immediately take the appropriate actions, avoiding the power from being turned off and reducing energy consumption.

Using IoT, data is logged in real time every 15 seconds and saved on a server. As a result, the user may check his power usage and recharge statistics at any time via the web interface. There is no need to manually monitor power use by glancing at a meter. If each meter's real-time power consumption data is accessible, it may be utilized for power consumption analysis. Because it is wireless and simple to set up, we can install it anywhere, including a business, residential, or municipal facility. We may also implement a public energy supply system, which reduces energy waste by using just the necessary energy on a regular basis. It is highly accurate with public power sources since the entire idea of reading the units and then invoicing manually or by any other means is eliminated.

### VII. CONCLUSION

Customers may pay for power before it is consumed with the planned prepaid energy meter, which is based on the Internet of Things. It minimizes the amount of time that humans spend reading meters and calculating bills. Consumers keep credit under control and then use electricity until the credit is gone. When the available credit is spent, a relay automatically turns off the power. When a user's credit goes below a specific threshold, GSM communication is used to alert them. Finally, this method resolves many of the difficulties associated with the post-payment billing system. Billing is also automated using this system.

### REFERENCES

- [1]. Arif, Anmar, et al. "Experimental study and design of smart energy meter for the smart grid." 2013 International Renewable and Sustainable Energy Conference (IRSEC). IEEE, 2013.
- [2]. Karthick, T. and Chandrasekaran, K., 2021. Design of IoT based smart compact energy meter for monitoring and controlling the usage of energy and power quality issues with demand side management for a commercial building. *Sustainable Energy, Grids and Networks*, 26, p.100454.
- [3]. Preethi, V. and Harish, G., 2016, August. Design and implementation of smart energy meter. In 2016 International Conference on Inventive Computation Technologies (ICICT) (Vol. 1, pp. 1-5). IEEE.
- [4]. Rahman, M.M., Islam, M.O. and Salakin, M.S., 2015, May. Arduino and GSM based smart energy meter for advanced metering and billing system. In 2015 International Conference on Electrical Engineering and Information Communication Technology (ICEEICT) (pp. 1-6). IEEE.
- [5]. Das, H. and Saikia, L.C., 2015, June. GSM enabled smart energy meter and automation of home appliances. In 2015 International Conference on Energy, Power and Environment: Towards Sustainable Growth (ICEPE) (pp. 1-5). IEEE.
- [6]. Rupesh, M. and Selvan, N.A., 2021, July. Design of IoT Based Smart Energy Meter for Home Appliances. In *Journal of Physics: Conference Series* (Vol. 1964, No. 5, p. 052001). IOP Publishing.
- [7]. Muralidhara, S., Hegde, N. and Rekha, P.M., 2020. An internet of things-based smart energy meter for monitoring device-level consumption of energy. *Computers & Electrical Engineering*, 87, p.106772.
- [8]. Khan, J.A. and Nagaraj, M.S., 2017. Research advancements towards in existing smart metering over smart grid.
- [9]. Regassa, B., Medina, A.V., Gómez, I.M., Rivera, O. and Gómez, J.A., 2011, March. Upgrading of traditional electric meter into wireless electric meter using ZigBee technology. In *International Conference on IT Revolutions* (pp. 84-94). Springer, Berlin, Heidelberg.