

Design and Analysis Of Bidirectional Buck-Boost Converter For DC Machine and BLDC Machine For Based Electrical Vehicle

Kunda Swapna¹, Mr. P. Venkateswara Rao².

ABSTRACT

It is necessary that alternating sources for oil reserves that are exhaustible in future need to be found. Due to combustion of oil, it will create environmental pollution problem. Most of the vehicles now a day are dependent on internal combustion engine for their operation which is cause of worry because they are responsible for air pollution so, vehicle manufacturer now a day are looking for alternative sources that can reduce pollution. Due to arising problem of pollution plug in hybrid electric vehicles are very essential for the future. As we know that a brushed DC motor uses a configuration of wound wire coils, the armature, acting as a two-pole electromagnet. A brushless motor, by contrast, utilizes a permanent magnet as its external rotor. In addition, it uses three phases of driving coils and a specialized sensor that tracks rotor position This project provides the comparative analysis of DC machine powered electric vehicle and BLDC powered electric vehicle and corresponding effect on state of charge and ripples in the dc voltage at the battery. This comparison is carried out in the MATLAB software comparative results are given individually.

INTRODUCTION

Transportation sector occupies a fundamental place in the world. Fossil fuels used in conventional vehicles technology emit greenhouse gases such as carbon dioxide, carbon monoxide and methane. The excessive consumption of these gases causes air pollution, climate change and global warming. In order to reduce these effects, there is a tendency to electric vehicle (EV) technology. The EV has much lower fuel cost according to fossil fueled car since they are mainly composed of battery system, power electronic circuits and electric machine. The battery system in an EV is the most crucial component in charge control time and determining distance [1,2]. The electric machines of an EV are operated in both motor and generator modes due to regenerative braking feature that enables electric machine to be operated in generator mode which is impossible in conventional internal combustion engine (ICE) vehicles. Therefore, electric

machine charges the battery by operating in generator mode during the regenerative braking and it ensures recharging the batteries [3,4]. EV are classified into two types as hybrid EVs (HEVs) and all-electric vehicles. The HEV technology is used in conjunction conventional vehicle technology. The main system in HEV technology includes fuel tank and ICE such as diesel or gasoline engine, and auxiliary system which is comprised by electric machine, power electronic circuits and battery. HEVs are classified as parallel and series hybrid vehicles [5] that the parallel HEV consists ICE and electrical machine together as shown in Fig.1. As the parallel electric vehicles operates at electric mode during the acceleration of electric machine, the motor operation is supplied from battery

The designed EV motor driver is comprised by four sections such as battery, bi-directional dc-dc converter, FLC and dc machine as shown In this study, the starting voltage of battery is set to 378 V

while the operating voltage of dc machine used in traction system is 500 V dc. The battery voltage is increased up to 500 V with bi-directional dc-dc converter in generator mode. The battery is discharged when dc machine is started acceleration. The motor mode simulation with various torque values are performed to observe battery parameters such as state of charge (SoC), current, voltage and voltage of the dc machine. The voltage of the dc machine is decreased to 500 V with bidirectional dc-dc converter which is controlled with FLC. The battery is charged during the generator mode operation of dc machine.

The FLC determines duty cycle of S1 and S2 to ensure charge and discharge of battery. The dc machine is comprised by brushes, armature core and windings, commutator, field core and windings. Armature circuit is comprised by series structure with inductor, resistance and counter-electromotive source. Similarly, battery parameters such as SoC, current, voltage and voltage of the dc machine are observed in the generator mode simulation regarding to various torque values applied to dc machine.

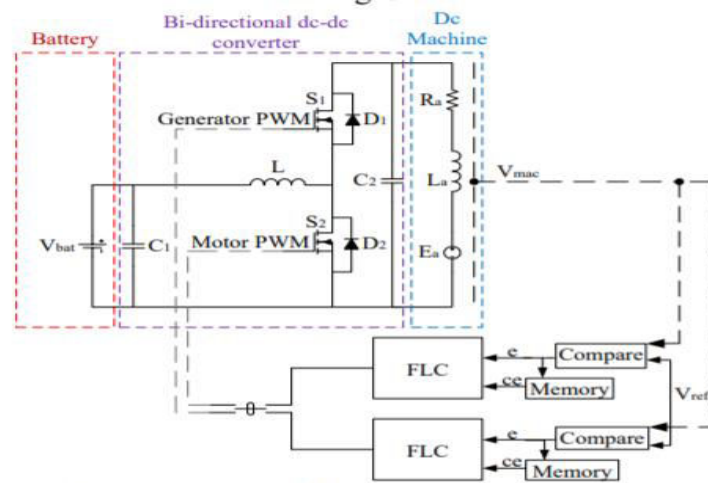

Fig 1 conventional circuit configuration

LITERATURE SURVEY

The electrical energy is converted to mechanical energy or vice versa by dc machine that operates regarding to electromechanical energy conversion theory [7]. If a conductor is moved within the magnetic field, the voltage is induced on it which is known as generator operating mode. If alternating current passes through the conductor, magnetic field is created around it which explains the motor mode operation. When the dc machine is started acceleration, the resultant positive torque is achieved. On the other hand, negative torque is generated at the dc machine when it is operated in generator mode

FLC is comprised by fuzzification, rule base, interface mechanism, defuzzification. Fuzzification is used to convert digital signals received through the system into linguistic variable. Rule base is comprised by the conditions to set for controlling the system at desired location. Interface mechanism makes inferences according to the rules of system by establishing a relationship between inputs. Defuzzification is used to convert linguistic variable received through the system into digital signals

The European new vehicle CO2 regulation (with a mandatory target value of 95 grams of CO2 per kilometer by 2021 for passenger cars) is currently in the process of being extended to 2025. In this

context, one of the key questions is at what point a significant uptake of the electric vehicle market is to be expected. In order to help inform this debate about how electric vehicle technology could fit in a lower-carbon 2020–2030 new vehicle fleet in Europe, this paper focuses on collecting, analyzing, and aggregating the available research literature on the underlying technology costs and carbon emissions. In terms of technologies, this paper concentrates on the three electric propulsion systems: battery electric vehicles (BEVs), plug-in hybrid electric vehicles (PHEVs), and hydrogen fuel cell electric vehicles (HFCEVs). The collected cost data is used to estimate the technology cost for automotive lithium-ion (Li-ion) batteries and fuel cells.

PROPOSED SYSTEM

The cost of battery packs for BEVs declined to an estimated €250 per kWh for industry leaders in 2015. Further cost reductions down to as low as €130–€180 per kWh are anticipated in the 2020–25 time frame. The costs of fuel cell systems are also expected to decrease considerably, but cost estimates are highly uncertain. Furthermore, the application of fuel cells and batteries in HFCEVs, BEVs, and PHEVs is approximated using a bottom-up cost approach. Overall, the different power train costs largely depend on battery and fuel cell costs. This paper concludes that

the costs of all power trains will decrease significantly between 2015 and 2030 (Figure S 1). As shown, power trains for PHEVs will achieve about a 50% cost reduction, compared with approximate cost reductions of 60% for BEVs and 70% for HFCEVs. Costs for hydrogen and electricity chargers are estimated separately. Greenhouse gas (GHG) emissions and energy demand for electric and conventional vehicles are presented on a well-to-wheel (WTW) basis, capturing all direct and indirect emissions of fuel and electricity production and vehicle operation. The results are based on former analyses, and are updated and refined with real-world fuel consumption levels. Real-world fuel consumption is commonly about 20%–40% higher than official typeapproval measurements. Finally, WTW estimates for electric and conventional vehicles are put in the context of the 2021 CO₂ standard for European passenger vehicles. It is found that carbon emissions of BEVs using European grid-mix electricity are about half of average European vehicle emissions, whereas HFCEVs and PHEVs have a lower emissions reduction potential. In the 2020 context, electric vehicle WTW emissions are expected to continue offering greater carbon benefits due to more efficient power trains and increasing low-carbon electric power.

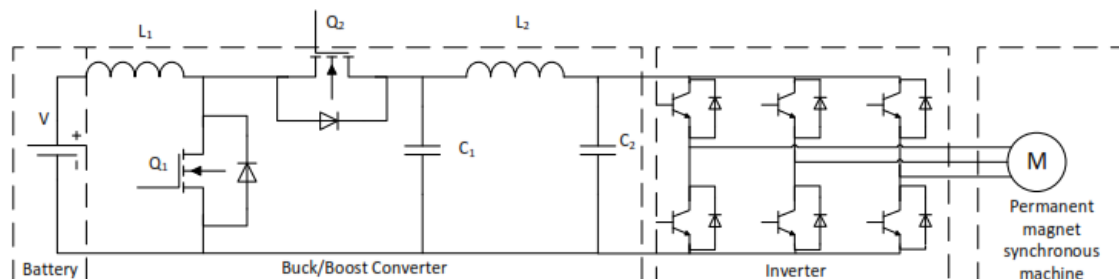

Fig 2 Proposed circuit configuration

A lower-carbon grid and higher power train efficiency by 2020 could cut average electric vehicle emissions by one-

third again. However, the expected cost reductions and potential CO₂ emission cuts will not be achieved without targeted



policy intervention. More stringent CO₂ standards, and fiscal and non-fiscal incentives for electric vehicles, can help the electric vehicle market to grow and costs to fall. Also, efforts need to be combined with activities to decarbonize the grid, or emission reductions will not be as great as they could be. Although the analysis is focused on the European context, similar dynamics with electric vehicle technology, policy, and market development are prevalent across major markets in North America and Asia.

The first EVs were introduced as early as 1838—or 52 years before internal combustion engine vehicles (ICEVs) entered the market. Despite recent growing interest, EVs have remained a relatively small market until today (IEA, 2015). However, the global share of EVs is expected to increase significantly, driven by substantial battery technology improvements and a variety of policies that are accelerating the development of the electric vehicle market. Overall, the market has grown from just hundreds of EV sales in 2010 to more than 500,000 sales worldwide in 2015 (EV Sales, 2016). The early development of markets for electric vehicles is seen predominantly in parts of China, Europe, and the United States, where electric vehicle support policies are helping promote the technology, while costs are still relatively high compared with conventional vehicles. Table 1 shows the global and regional estimated stock of BEV and PHEV passenger cars as of 2015, and electric vehicle supply equipment (EVSE) as of 2014. EVSE includes semipublic or public charging points or outlets, but not private charging points. Most of the electric vehicles on the road today are registered in the United States, with about half of those in the state of California. The United States also has the largest number of electric vehicle charging points. The

Netherlands is the European country with the highest electric vehicle passenger car and charging-plug stock in terms of absolute sales. The following countries have achieved relatively high market sales shares of passenger electric vehicles, as a percentage of all 2014 passenger vehicle sales: Norway (13.7%), the Netherlands (3.9%), Sweden (1.5%) (Mock, 2015), and the United States (1.5%) (Lutsey, 2015b). Most other major automobile markets have EV sales shares at or below 1%.

Pure battery electric vehicles (BEVs) are also referred to as battery-only electric vehicles (BOEVs). BEVs have no engine and are propelled by electricity that comes from one or several onboard high-energy batteries. Modern models use a regenerative braking system to save energy. Examples include the Renault Zoe and the Nissan Leaf. The Zoe has a 22 kWh Li-ion battery, and an energy consumption of 14.6 kWh per 100 km, which yields a range of about 140 km to 210 km per battery charge on the New European Driving Cycle (NEDC). The 2015 Leaf comes with a 24 kWh battery (plus a 30 kWh option for the 2016 model), and an official consumption of 15 kWh per 100 km.

3.2. PHEVs

Plug-in hybrid electric vehicles (PHEVs) allow electric driving on batteries (in charge-depleting mode), but also conventional combustion-fueled driving (in charge-sustaining mode). Usually, they are equipped with an electric motor and a high-energy battery, which can be charged from the power grid. Modern PHEVs can be driven in electric mode over varying distances before the combustion engine is required. In electric-driving mode, the energy efficiency of the propulsion system is much higher, and is comparable to that of a BEV. Available models include the Chevrolet Volt in U.S. markets (which is the Opel Ampera in EU markets), and the Toyota Prius Plug-in Hybrid. The 2015

Opel Ampera uses a 16 kWh Li-ion battery and consumes 16.9 kWh per 100 km in electric mode on the NEDC. The 2015 Chevrolet Volt has a 16.5 kWh battery, and the 2016 model has an 18.4 kWh battery

PHEVs and BEVs use similar batteries, with Li-ion being the most common chemistry. There are two primary ways to extract the lithium used in batteries: mining spodumene and petalite ore using evaporation ponds on salt lakes. The majority of lithium is obtained from brine operation (USGS, 2015). The battery system is the key technology of electric vehicles and defines their range and performance characteristics. The battery works like a transducer by turning chemical energy into electrical energy. Li-ion is expected to be the dominant chemistry for BEVs and PHEVs for the foreseeable future, as most research is done in the field of Li-ion batteries. They provide relatively high power and energy for a given weight or size, and can significantly reduce costs compared with other battery concepts. Energy density of

the battery pack is estimated to roughly double, up to about 300 Wh per kg, between 2007 and 2030 (Kromer & Heywood, 2007; Ricardo-AEA, 2015; NAS, 2013). Also, they have a relatively long life cycle and low selfdischarging losses. One of their few drawbacks is their sensitivity to overcharging, which is why they require a battery management system. Other automotive battery concepts include nickel-metal hydride (Ni-MH), sodium-nickel chloride (Na/NiCl₂), and non-electrochemical alternatives such as supercapacitors, which allow fast charging but provide low energy density. As a result, batteries with higher energy and power densities are being developed, such as lithiumair (Li-air), lithium-metal or lithiumsulphur (Li-S), but these are far from commercialization (Cookson, 2015; Hacker, Harthan, Matthes & Zimmer, 2009). Li-air batteries may reach energy densities of up to 11,680 Wh per kg (Imanishi & Yamamoto, 2014), which approximates the energetic content of gasoline.

SIMULATION RESULTS

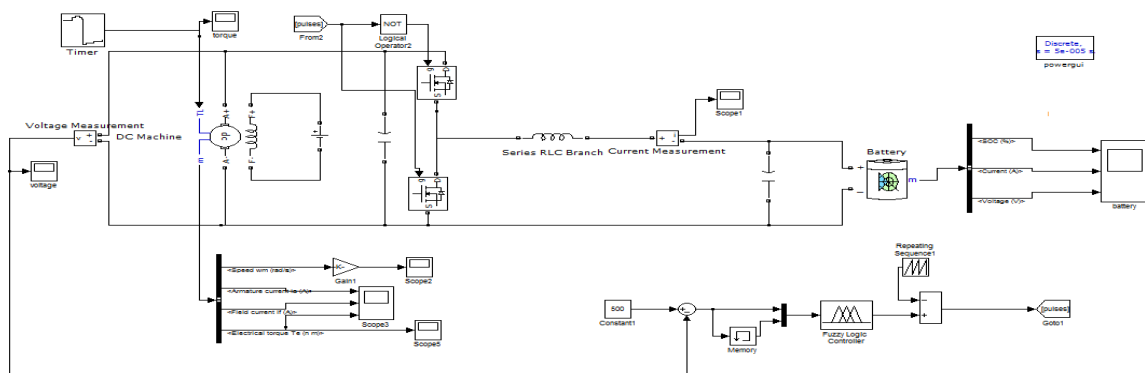

Fig 3 Proposed circuit configuration

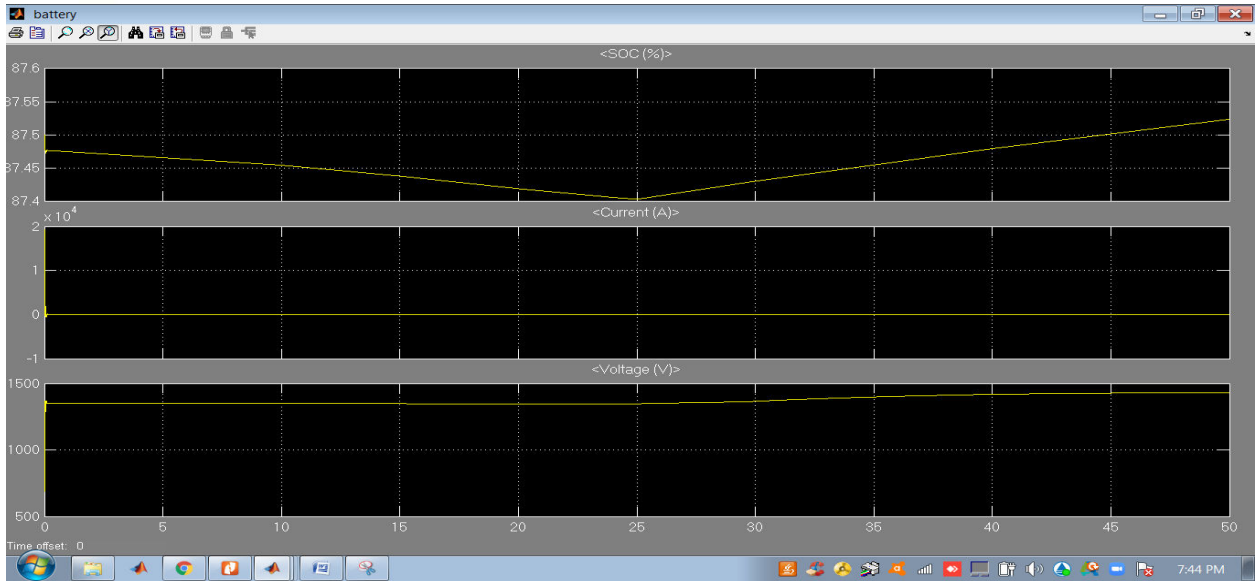

Fig 4 Proposed system Battery SOC, current, voltage

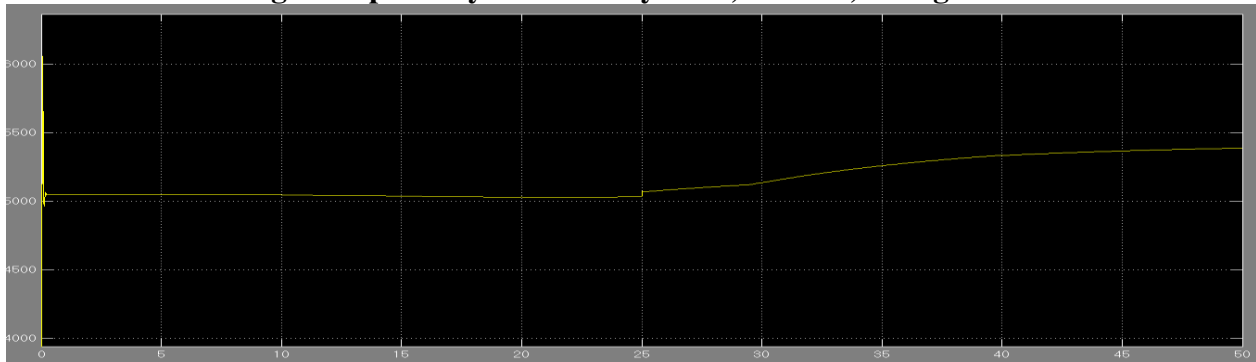

Fig 5 Proposed system Speed of the dc machine

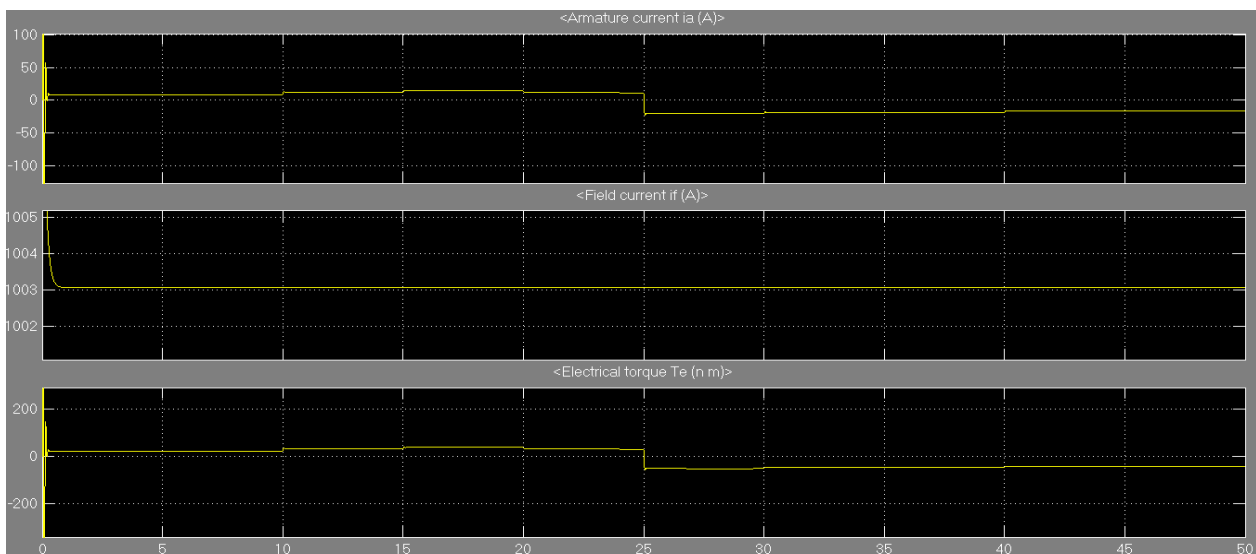

fig 6 Proposed system Armature current, Field current, Electro magnetic torque

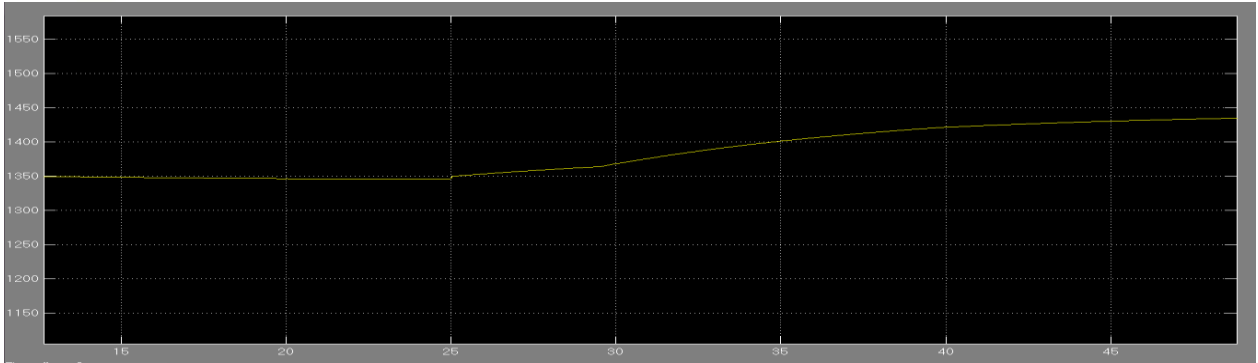

Fig 7 Proposed Dc machine across voltage

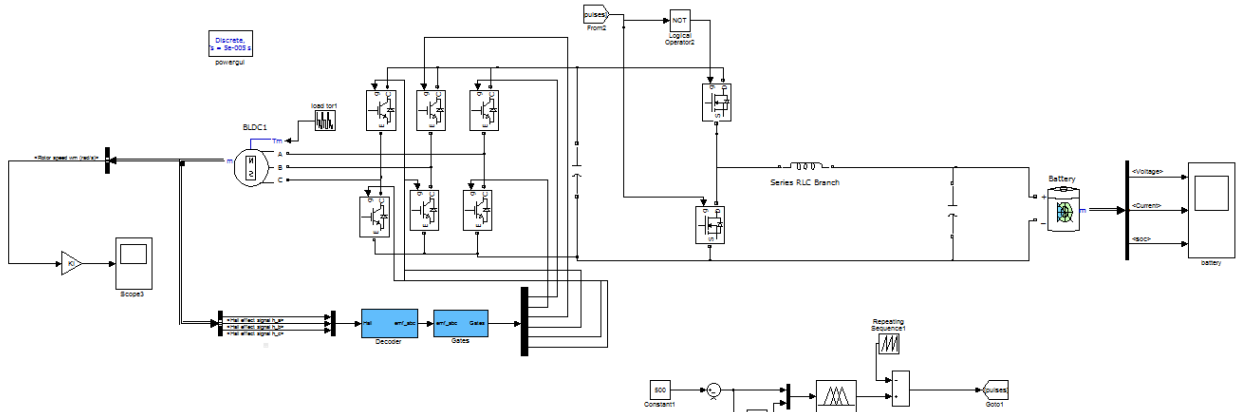

Fig 8 Proposed system with BLDC motor

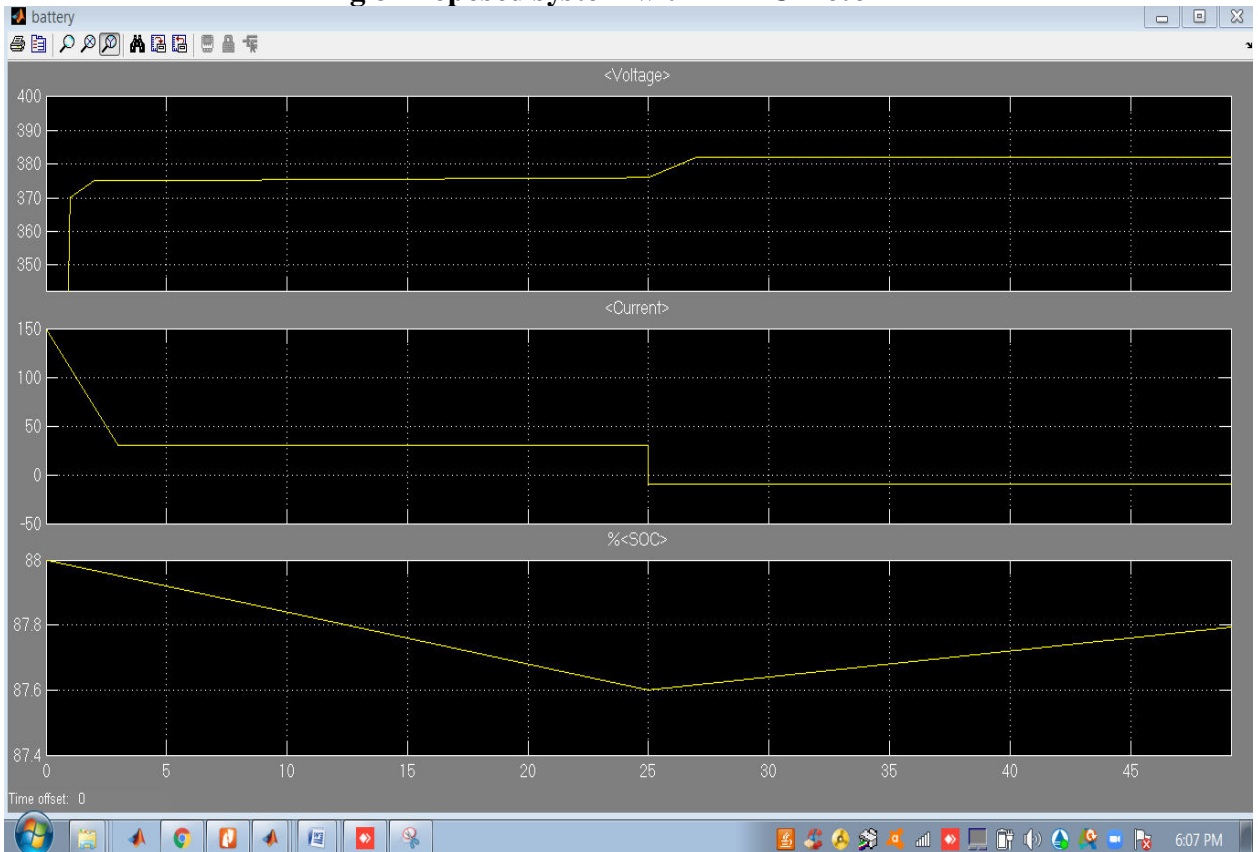

Fig 9 Battery voltage, current and SOC



CONCLUSION

When the battery is charged, the dc machine is operated generator mode and bi-directional dc-dc converter is operated in buck mode. Variable negative torque values are applied to the dc machine and effect on the battery is observed. According to simulation result, the battery SoC is increased from 87.47% to 87.55%. In all-electric vehicle, regenerative braking is occurred in this state. Charge and discharge states of the battery are the most essential for distance to determining. When the battery is charged, the dc machine is operated generator mode and bi-directional dc-dc converter is operated in buck mode. Variable negative torque values are applied to the BLDC machine and effect on the battery is observed. According to simulation result, the battery SoC is increased from %88 to %87.8. In all-electric vehicle, regenerative braking is occurred in this state. Charge and discharge states of the battery are the most essential for distance to determining.

REFERENCES

- [1] F. Zhang, X. Zhang, M. Zhang and A. S. E. Edmonds, "Literature review of electric vehicle technology and its applications," 2016 5th International Conference on Computer Science and Network Technology (ICCSNT), Changchun, 2016, pp. 832-837.
- [2] A. Tiwari and O. P. Jaga, "Component selection for an electric vehicle: A review," International Conference on Computation of Power, Energy Information and Commuincation (ICCPEIC), Melmaruvathur, 2017, pp. 492-499.
- [3] Jia Ying Yong, Vigna K. Ramachandaramurthy, Kang Miao Tan, N. Mithulananthan, "A review on the state-of-the-art technologies of electric vehicle, its impacts and prospects," Renewable and Sustainable Energy Reviews, vol: 49, 2015, pp: 365-385
- [4] X. Nian, F. Peng and H. Zhang, "Regenerative Braking System of Electric Vehicle Driven by Brushless DC Motor," in IEEE Transactions on Industrial Electronics, vol. 61, no. 10, pp. 5798-5808, Oct. 2014.
- [5] Yanzhi Wang, Xue Lin, M. Pedram and N. Chang, "Joint automatic control of the powertrain and auxiliary systems to enhance the electro mobility in hybrid electric vehicles," 2015 52nd ACM/EDAC/IEEE Design Automation Conference (DAC), San Francisco, CA, 2015, pp. 1-6.
- [6] J. Zhang, T. Shen, Receding Horizon "Optimal Control of PHEV with Demanded Torque Estimation Model," IFAC-PapersOnLine, Volume 51, vol: 31, 2018, pp: 183-187
- [7] Z. Haishui, W. Dahu, Z. Tong and H. Keming, "Design on a DC Motor Speed Control," 2010 International Conference on Intelligent Computation Technology and Automation, Changsha, 2010, pp. 59-63.
- [8] S. J. Chapman, Electric Machine Fundamentals. New York: McGrawHill, 2005.
- [9] J. Shen and A. Khaligh, "An energy management strategy for an EV with two propulsion machines and a hybrid energy storage system," IEEE Transportation Electrification Conference and Expo (ITEC), Dearborn, MI, 2015, pp. 1-5.
- [10] M. S. Perdigão, J. P. F. Trovão, J. M. Alonso and E. S. Saraiva, "Large-Signal Characterization of Power Inductors in EV Bidirectional DC-DC Converters Focused on Core Size Optimization," IEEE Transactions on Industrial Electronics, vol. 62, no. 5, 2015, pp. 3042-3051.
- [11] L. Albiol-Tendillo, E. Vidal-Idiarte, J. Maixé-Altés, J. M. BosqueMoncusí and H. Valderrama-Blaví, "Design and control of

a bidirectional DC/DC converter for an Electric Vehicle,” 15th International Power Electronics and Motion Control Conference (EPE/PEMC), Novi Sad, 2012, pp.2-5

[12] I. Azizi and H. Radjeai, “A bidirectional DC-DC converter fed DC motor for electric vehicle application,” 4th International Conference on Electrical Engineering (ICEE), Boumerdes, 2015, pp. 1-5.

[13] R. Cipin, M. Mach, M. Toman and J. Knobloch, “Measurement and evaluation of DC motor starting torque,” 2017 IEEE International Conference on Environment and Electrical Engineering and 2017 IEEE Industrial and Commercial Power Systems Europe (EEEIC / I&CPS Europe), Milan, 2017, pp. 1-5.

[14] Premananda P., Singh R.K, Tripathi R.K. “Bidirectional DC-DC converter fed drive for electric vehicle system,” International Journal of Engineering, Science and Technology vol. 3, no. 3, 2011, pp. 101- 110

[15] R. H. G. Tan and L. Y. H. Hoo, “DC-DC converter modeling and simulation using state space approach,” 2015 IEEE Conference on Energy Conversion (CENCON), Johor Bahru, 2015, pp. 42-47.

[16] Modabbernia, M. R., Sahab, A. R., Mirzaee, M. T., & Ghorbany, K. “The

State Space Average Model of Boost Switching Regulator Including All of the System Uncertainties,” Advanced Materials Research, vol: 403, 2012, pp: 3476–3483.

[17] M. S. Perdigão, J. P. F. Trovão, J. M. Alonso and E. S. Saraiva, “Large-Signal Characterization of Power Inductors in EV Bidirectional DC–DC Converters Focused on Core Size Optimization,” in IEEE Transactions on Industrial Electronics, vol. 62, no. 5, 2015, pp. 3042-3051,

[18] Suresh, K., and R. Arulmozhiyal. “Design and Implementation of BiDirectional DC-DC Converter for Wind Energy System,” Circuits and Systems, vol: 17 2016 pp: 3705-3722.

[19] R. Bayindir, I. Colak, E. Kabalci and E. Irmak, “The Fuzzy Logic Control of a Multilevel Converter in a Variable Speed Wind Turbine,” 2009 International Conference on Machine Learning and Applications, Miami Beach, FL, 2009, pp. 787-790

[20] Oscar Cordón, “A historical review of evolutionary learning methods for Mamdani-type fuzzy rule-based systems: Designing interpretable genetic fuzzy systems,” International Journal of Approximate Reasoning, Volume 52, Issue 6,2011, pp 894-913



Kunda Swapna, PG Scholar from Department of EEE in Amrita Sai Institute of Science and Technology, paritala, at kanchicharlaMandal, Krishna-Dist, Andhra Pradesh, India.



Mr. P. Venkateswara Rao. He received his B.Tech degree degree in Electrical and Electronics Engineering from Amrita Sai Institute of Science and Technology, Paritala, Ap, India in 2014. M. Tech degree Power Electronics in Amrita Sai Institute of Science and Technology, paritala, Ap, India in 2018,he currently working as a assistant Professor in Amrita Sai Institute of Science and Technology, Paritala, Ap. His intrest research area are power electronic applications to ASDs.