



A SEPIC CONVERTER APPLICATION IN WIND POWER DEVICES TO EXPAND THE SPEED RANGE OF DUAL-STATOR WINDING INDUCTION GENERATORS

Mr. S NANI BABU¹, K L SAHITHI², S ISHWARYA MADHURI³, K BHARATH⁴,
P H V N VARAPRASAD⁵, U PRAVEEN KUMAR⁶, K SYAMALA DEVI⁷

¹Assistant Professor, Dept. of EEE, PRAGATI ENGINEERING COLLEGE

^{2,3,4,5,6,7}UG Students, Dept. of EEE, PRAGATI ENGINEERING COLLEGE

ABSTRACT

In this article, a topology for the variable speed wind power application is suggested using a Dual-stator Winding Induction Generator (DWIG) and a boost converter. The generator overload restricts the DWIG voltage at low rotor velocities. Even in low speed and low voltage situations, the DWIG can function at Maximum Power Point Tracking (MPPT) by using a boost converter to generate a higher DC voltage. The Control-Winding Voltage Oriented Control (CWVOC) technique is used by the Semiconductor Excitation Controller (SEC) of the DWIG to modify the voltage while taking V/f characteristics into consideration. The method for multiple processes that is suggested includes the sepic converter. The suggested control approach uses two decoupled control circuits, one for dc load voltage modulation and the other for low-voltage source (LVS) current control. The relative gain array theory (RGA) of multi-input-multi-output control systems is then applied to establish workable combinations of input and output quantities, as well as control and power distribution quantities, in order to achieve optimal load allocation to input sources. First, a discrete-time model of the proposed converter is established. When examining the wind turbine power-speed curve, the V/f strategy, and the generator factors when analyzing the SEC reactive current for the suggested topology, the SEC capacity and the excitation capacitor are optimized. The technique demonstrates that the per-unit capacity of the SEC can be restricted to the negative of the per-unit value of DWIG magnetizing reactance. The broad variable speed operating range of the DWIG is shown by the modelling findings, which also validate the optimization.

INTRODUCTION

These days, wind power generation is being looked at as a potential replacement for the traditional power plants that run on fossil fuels. More interest is being drawn to it as a result of the fact that more than fifty percent of the total capacity of wind turbines has been installed in the last five years. As a result of the early wind turbine technology being based on squirrel cage induction

generators (SCIG) that were directly connected to the grid, the rotor speed has remained rather consistent over the years. In today's modern wind turbine technologies, variable speed generator systems are preferred by turbine designers. This is due to the problems associated with gearboxes as well as the maximization of wind power extraction. Electronic power converters make it possible for generators to run at



varying speeds, and these converters can be used in wind power systems as well.

The Doubly-Fed Induction Generator (DFIG) or the Permanent Magnet Synchronous Generator is the foundation for the vast majority of variable speed wind turbine systems (PMSG). While the PMSG-based wind turbine has a better power density and efficiency, its disadvantages include a higher cost of generator raw materials and a higher price for the full-rated converter. The slip-ring and brush configuration of the DFIG-based systems results in decreased efficiency and higher maintenance costs, while the price of the generator and partial-rated converter is reduced. There is an increasing desire for the installation of wind turbines offshore, where there is also an advantage due to the superior wind conditions. This demand is being driven by environmental concerns as well as social and political restraints.

High Voltage Direct Current (HVDC) transmission is the most cost-effective method of power transfer for large-scale offshore wind farms that are located far from the coast. Throughout the research that has been done so far, there have been a number of viable options offered for integrating wind turbines with HVDC transmission systems. The integration of DFIG and PMSG-based wind turbines with HVDC has been analyzed and explored in those research. The DFIG-based system requires an additional AC/DC converter for the application, which results in an increase in the total cost of the investment. In addition, the cost of maintenance for DFIG

systems used in offshore wind farms is higher. Despite the fact that the PMSG-based wind turbine has a high initial investment cost, it is highly recommended that generators with DC output voltage be integrated with HVDC systems. This is due to the higher efficiency, higher Annual Energy Production (AEP), lower maintenance costs, and absence of a need for additional AC/DC converters and. In recent years, a Dual-stator Winding Induction Generator (DWIG) DC generation system has been proposed in the literature for the variable speed applications such as offshore wind power system, ship propulsion, and aircraft generation system. DWIG stands for Dual-stator Winding Induction Generator, which stands for Dual-stator Winding Induction Generator.

PROPOSED TOPOLOGY

In the wind power application, to ensure that the wind turbine tracks the maximum power point (MPP), variable speed operation is required. Particularly, in low wind speed condition, to increase the output power, the generator must work at low speed, to increase the blade aerodynamic efficiency. This operation increases the annual energy output and decreases the time period of investment return. The wind turbine power-speed curves for various wind speeds in which each curve has its MPP at a specified speed. So, one of the main objectives of the control system is to adjust the generator speed at the optimal value. In this paper, a boost converter is utilized in the DWIG based system to control the generator speed for MPPT purpose in a wide speed range.

The topology employs a squirrel cage induction generator with two sets of stator windings, wound in the same stator slots and both are star-connected 3-phase winding with the same number of poles. One is the control-winding, which is used to control the generator excitation and supply a part of generator reactive power. The other is power-winding used for active power generation. Nevertheless, some part of the generator reactive power is provided through the power winding by the excitation capacitor (C_{exc}).

In the control-winding side, a voltage source converter, named SEC, is connected to the winding via a coupling inductor (L_{SEC}). Also, a low voltage battery with a series diode is connected to DC side of SEC to charge the capacitor for the system start-up. At normal operation, SEC regulates its DC link voltage (V_{dc}) to a specific reference value, which is more than the battery voltage, so the diode is reverse biased. The main role of SEC is regulation of the control-winding voltage. Meanwhile, the frequency is controlled according to the generator speed and the slip frequency which is imposed by the load. To generate electrical energy at the low-speed conditions, where the frequency is low, magnetic saturation of the generator is the main limitation. In such condition, the SEC decreases the amplitude of the control-winding voltage according to V/f strategy to avoid saturation. In the power-winding side, there is a 3-phase diode rectifier and an excitation capacitor. The output DC-link of the diode rectifier is directly connected to a

boost converter. The diode rectifier converts the variable amplitude and frequency voltage of the power-winding into a DC voltage (V_{B1}), and then the boost converter adjusts the output power at the MPP, according to the power-speed curve. This can be performed by controlling the boost converter input current (I_{B1}), which leads to the control of the generator power-winding current, as well as the generator power. The output voltage of the boost converter is regulated at a higher constant value by a grid connected converter to inject the generated power to the AC network. In addition, the boost converter output can be connected to a DC network with a higher voltage such as HVDC.

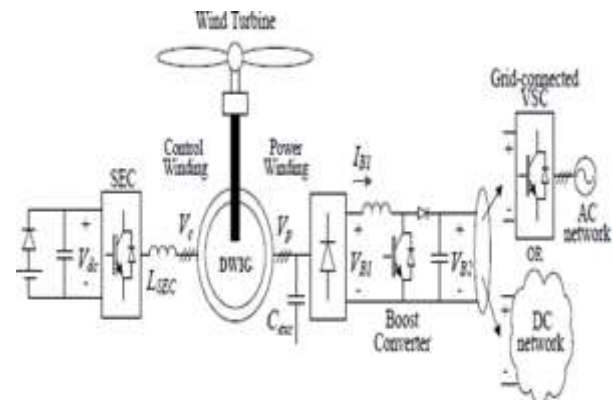

Fig 1 Proposed circuit configuration

The sepic converter is involved in the proposed system for multi operations. The proposed control strategy involves two decoupled control loops: one for low-voltage source (LVS) current control and the other for dc load voltage regulation. A discrete-time model of the proposed converter is established, and then, the relative gain array theory (RGA) of multi-input-multi-output control systems is applied to establish feasible combinations of



input and output quantities, as well as control and power distribution quantities, for achieving optimal load allocation to input sources.

Wind is abundant almost in any part of the world. Its existence in nature caused by uneven heating on the surface of the earth as well as the earth's rotation means that the wind resources will always be available. The conventional ways of generating electricity using non-renewable resources such as coal, natural gas, oil and so on, have great impacts on the environment as it contributes vast quantities of carbon dioxide to the earth's atmosphere which in turn will cause the temperature of the earth's surface to increase, known as the greenhouse effect. Hence, with the advances in science and technology, ways of generating electricity using renewable energy resources such as the wind are developed. Nowadays, the cost of wind power that is connected to the grid is as cheap as the cost of generating electricity using coal and oil. Thus, the increasing popularity of green electricity means the demand of electricity produced by using non-renewable energy is also increased accordingly.

Kinetic energy from the wind is used to turn the generator inside the wind turbine to produce electricity. There are several factors that contribute to the efficiency of the wind turbine in extracting the power from the wind. Firstly, the wind speed is one of the important factors in determining how much power can be extracted from the wind. This is because the power produced from the

wind turbine is a function of the cubed of the wind speed. Thus, the wind speed if doubled, the power produced will be increased by eight times the original power. Then, location of the wind farm plays an important role in order for the wind turbine to extract the most available power from the wind.

The next important factor of the wind turbine is the rotor blade. The rotor blades length of the wind turbine is one of the important aspects of the wind turbine since the power produced from the wind is also proportional to the swept area of the rotor blades i.e. the square of the diameter of the swept area.

Disadvantages in Conventional method:-

- For low voltage sources we use boost converters
- For high voltage sources we use buck converters
- Extra floating switch required
- increased complexity and cost
- Discontinuous input current in Buck region

- To overcome these problems Instead if buck-boost converters in proposed system we use a sepic converter which has both boost and buck converters connected in parallel.

Uses of Sepic convertes:-

- Used for both low voltage and High voltage sources

- SEPIC is capable of operating from an input voltage that is greater or less than the regulated output voltage
- This capability allows it to be used in many non-isolated applications such as automotive, medical, security systems, and LED lighting

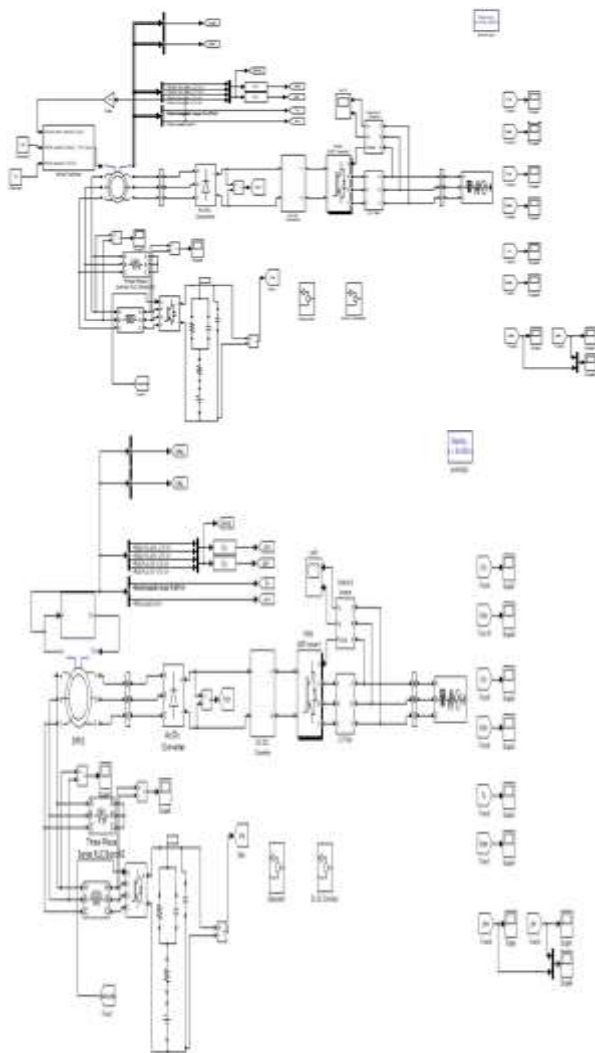

Fig 2 simulation circuit

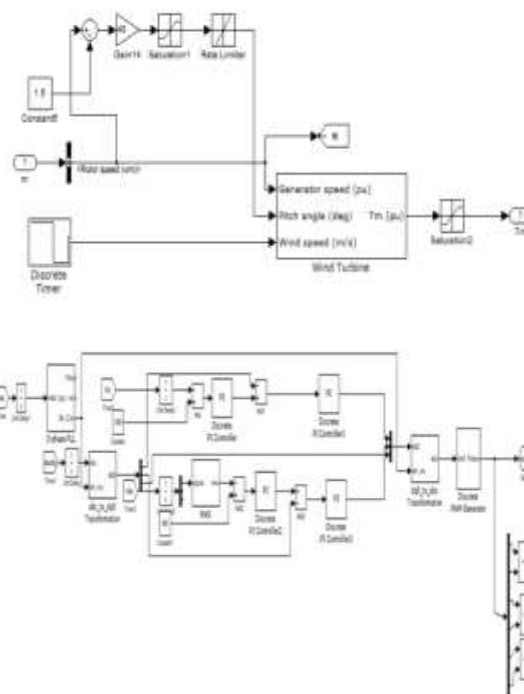

Fig 3 turbine model and control circuit

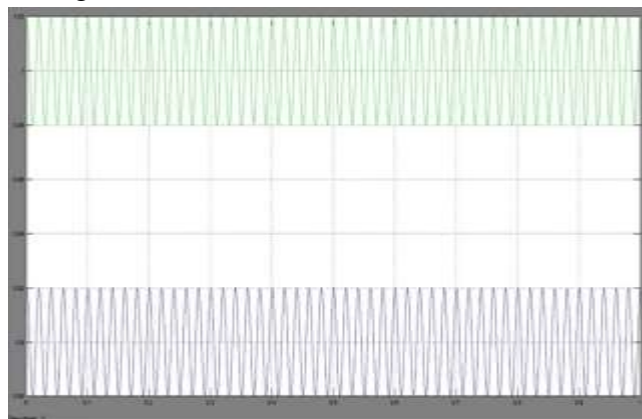

Fig 4 Dc link voltage and current

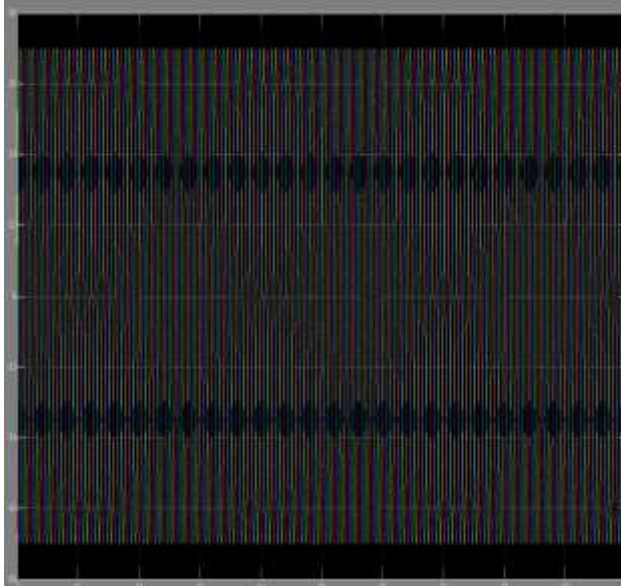

Fig 5 grid voltage

CONCLUSION

This paper proposes a topology for variable speed wind power application using dual stator-winding induction generator. A boost converter is utilized for MPPT and wide range variable speed operation, especially at low-speed condition is obtained. At low speeds, DWIG voltage is dropped due to V/f strategy and a boost converter is used to increase the voltage level to meet the higher and constant voltage requirement, such as in voltage source converter DC link or offshore DC network applications. In the proposed topology, by choosing the optimum excitation capacitor, the capacity of the semiconductor excitation controller is minimized. Finally, to verify the proper operation of the proposed system, simulation and experimental results are presented which validate the wide-speed range operation of the system and the excitation capacitor optimization method.

REFERENCES

- [1] Q. Zhou, M. Shahidehpour, et al, “Distributed Control and Communication Strategies in Networked Microgrids,” IEEE Communications Surveys & Tutorials, vol. 22, no. 4, pp. 2586- 2633, Fourth quarter 2020.
- [2] X. Zhao, J. M. Guerrero, et al, “Low-Voltage Ride-Through Operation of Power Converters in Grid-Interactive Microgrids by Using Negative-Sequence Droop Control,” IEEE Trans. Power Electron., vol. 32, no. 4, pp. 3128–3142, April 2017.
- [3] I. Sadeghkhan, M. E. H. Golshan, A. Mehrizi-Sani, J. M. Guerrero, “Low-voltage ride-through of a droop-based three-phase four-wire grid-connected microgrid,” IET Gener. Transm. Distrib., vol. 12, no. 8, pp. 1906–1914, 2018.
- [4] Y. He, M. Wang and Z. Xu, “Coordinative Low- Voltage-Ride-Through Control for the Wind-Photovoltaic Hybrid Generation System,” IEEE Journal of Emerging & Selected Topics in Power Electronics, vol. 8, no. 2, pp. 1503–1514, Jun. 2020.
- [5] Y. Yang, F. Blaabjerg, and Z. Zou, “Benchmarking of grid fault modes in single-phase grid-connected photovoltaic systems,” IEEE Trans. Ind. Appl., vol. 49, no. 5, pp. 2167–2176, Sep./Oct. 2013.
- [6] N. Jelani and M. Molinas, “Asymmetrical fault ride through as ancillary service by constant power loads in grid-connected wind farm,” IEEE Trans. Power Electron., vol. 30, no. 3, pp. 1704–1713, Mar. 2015.
- [7] P. P. Vergara, J. M. Rey, H. R. Shaker,



J. M. Guerrero, et al, “Distributed Strategy for Optimal Dispatch of Unbalanced Three-Phase Islanded Microgrids,” IEEE Trans. Smart Grid, vol. PP, no. 99, pp. 1-15, 2018.

[8] A. Micallef, M. Apap, and J. M. Guerrero, “Singlephase microgrid with seamless transition capabilities between modes of operation,” IEEE Trans. Smart Grid, vol. 6, no. 6, pp. 2736–2745, Nov. 2015.

[9] J. Chan, J. Milanovic, and A. Delahunty, “Generic failure-risk assessment of industrial processes due to voltage sags,” IEEE Trans. Power Del., vol. 24, no. 4, pp. 2405–2414, Oct. 2009.

[10] P. Prasanna, E. Mohammad, K. G. Masoud, A. K. Sayed, “Fault Ride-Through Capability of Voltage-Controlled Inverters,” IEEE Transactions on Ind. Electron., vol. 65, no. 10, pp. 7933- 7943, Oct. 2018.

[11] J. A. Laghari, H. Mokhlis, M. Karimi, A. H. A. Bakar, and H. Mohamad, “Computational intelligence based techniques for islanding detection of distributed generation in distribution network: A review,” Energy Convers. Manag., vol. 88, pp. 139–152, Dec. 2014.

[12] W. Wan, M. A. Bragin, B. Yan, Y. Qin, et al, “Distributed and Asynchronous Active Fault Management for Networked Microgrids,” IEEE Trans. Power System, vol. 35, no. 5, pp. 3857- 3868, Sep. 2020.

[13] A. Camacho, M. Castilla, J. Miret, L. G. de Vicuña, and R. Guzman, “Positive and negative sequence control strategies to

maximize the voltage support in resistive–inductive grids during grid faults,” IEEE Trans. Power Electron., vol. 33, no. 6, pp. 5362–5373, Jun. 2018.

[14] W.F. Wan, Y. Li, B. Yan, et al., “Active Fault Management for Microgrids,” Annual Conference of the IEEE Industrial Electronics Society (IECON), pp. 1-6, 2018.

[15] S.A. Gopalan, V. Sreeram, H. H.C.Iu, “A review of coordination strategies and protection schemes for microgrids,” Renewable and Sustainable Energy Reviews, vol. 32, pp. 222-228, April 2014.

[16] R. Li, L. Xu, Y. Yao, “DC Fault Detection and Location in Meshed Multiterminal HVDC Systems Based on DC Reactor Voltage Change Rate,” IEEE Trans. Power Del., vol. 32, no. 3, pp. 1516–1526, June. 2017.

1.