



AMBULANCE DETECTION AND TRAFFIC CLEARANCE USING RASPBERRY PI PICO

MONIKA CHOUDHARY¹, M.VARSHA², L.SWETHA³, MR.V.NAGAMAHESH⁴

^{1,2,3} UG Students, Department of ECE, *Malla Reddy Engineering College for Women (UGC-Autonomous) Maisammaguda, Hyderabad, Telangana, India.*

⁴ Assistant Professor, Department of ECE, *Malla Reddy Engineering College for Women (UGC-Autonomous) Maisammaguda, Hyderabad, India.*

ABSTRACT:

Existing time based traffic management system is not suitable, flexible for the present day traffic. Owing to this reason many emergency services like ambulance, fire services were prevented from doing their duty at the right time, keeping this in mind there were few methods proposed earlier such as timer based system. This would enable vehicle clearance for a certain amount of time and switch to the other side of the road. This did not hold good for the ambulance (emergency vehicles) as the waiting time is more if the timer is at some other road other than the one it is presently. Disadvantages of the previous methods, taking it as an advantage, we have proposed a method called “green wave “method where in the ambulance is fitted with a zigbee transmitter and controlled by a zigbee receiver using Arduino Uno micro-controller. Traffic light is fitted with a zigbee receiver and traffic signal are controlled by a micro –controller based on the received data. When Ambulance switches on the siren, zigbee transmitter transmits the signals and when it approaches traffic signal stand, zigbee receiver in the stand receives signals and automatically switches traffic signals to green thus making ambulance pass through the road intersections

Keywords: *Zigbee, Traffic lights, Mobile, WSN.*

1. INTRODUCTION:

With the development of technology, new vehicles that are more luxurious are emerging into the market. Everyone wishes to travel by these luxury vehicles for more console instead of public transportation. The ever-increasing demand of personal vehicles leads to crisis of more traffic on roads. The fast increase in the vehicle ownership is one of the measures for financial development of country but indirect result of vehicle ownership is severe traffic jam. The development of new trends and technologies

leads to rapid transportation of goods, machines and man power for different reasons. The aim of each one is to arrive at destination without wasting their time and money but resources provided by existing transportations are inadequate and are having poor performances. So the traffic management at intersection of the road is critical to diminish waiting and traveling times, save fuel and money The crisis of traffic jam encompass everywhere, but big cities are the ones that are most influenced



by it. The continually growing nature of traffic makes it hard to determine the road traffic density in real time so as to make better traffic related judgments and manage the traffic more efficiently. There are numerous reasons for this rapid flow in the traffic, in mega cities. The key reason can be assigned to increase in the population which in turn has caused increase in the number of vehicles on the road. Also there are several other reasons for congestion like inadequate capability of roads, fixed time interval of red and green lights leads to unnecessary delay in travel time, incomplete information about traffic, inefficient transport management, uncontrolled demand etc. Insufficient capacity and uncontrolled demand are interconnected but signal delays are inflexible and do not depend on the quantity of traffic density. As a result there is a necessity to optimize traffic control system and make it more dynamic so as to accommodate the changing traffic density. Cities became the identity for heavy traffic congestion and have appreciable economic development when compared to the development in rural areas. People in rural regions migrate towards urban areas for improving their standard of living. Cities have higher population density and the people living in urban areas enjoy more facilities than those living in rural areas. Time is the most crucial element in today's life. People like to spend more time in their work place rather than wasting time by commuting on road. City people mainly prefer their own transport for travel rather

than using public transport resulting in greater vehicle Population.

OVER VIEW:

Proposed work in the project includes, quick access to emergency vehicles time saving, Automatic Adjustment of traffic signals, less delay, Orderly movement of traffic reduces potential of conflicts and accidents ensures safety. This method can be used in various applications like that of congestion detection, intelligent traffic light system finding offended vehicles, public parking detection faster vehicle movement in case of emergencies. It can also be extended further by having a route navigator which helps to find the shortest route to reach the destination instead of messing up in traffic. For the Application download it from the Play store as it is available free of cost named "Serial USB Terminal" and set the bits and data accordingly to the priority of the project with supporting cables and wires. The proposed project helps to maintain a hassle free path and also saves a lot of time in the present day increase in technology for emergency vehicles.

2 RELATED STUDY

Advanced Transportation Management System research presented an overview of the design and function of the Intelligent Roadway Information System. Most ATMS programs are not suited to rural areas and IRIS presents a low-cost alternative that provides significant operational capabilities to rural districts. IRIS was developed by the Minnesota Department of Transportation and Caltrans has submitted functional enhancements to be integrated into the



official code. Full deployment to each rural district has been successful with a reduction in the number of traffic management software applications and servers in those districts. The “Intelligent Container” is a sensor network used for the management of logistic processes, especially for perishable goods such as fruit and vegetables. The system measured relevant parameters such as temperature and humidity. The concept of “cognitive systems” provides an adequate description of the complex supervision tasks and sensor data handling. According to research, the cognitive system can make use of several algorithms in order to estimate temperature related quality losses, detect malfunctioning sensors, and to control the sensor density and measurement intervals. Based on sensor data, knowledge about the goods, their history and the context, decentralized decision making is realized by decision support tools. The amount of communication between the container and the headquarters of the logistic company was reduced, while at the same time the quality of the process control was enhanced. The system is also capable of self-evaluation using plausibility checking of the sensor data. The main contribution of this research was to introduce traffic safety equity in transportation policy making. A modelling framework was developed that considered traffic safety equity as a focal point. The Analytical Network Process overcame the drawbacks of data intensive models that were so difficult to implement reliably in developing countries and recognizes the existence of complex inter dependencies

among traffic safety factors. The approach was demonstrated such that seventeen transportation elements were grouped into four clusters (driver characteristics, roadway characteristics, vehicle characteristics and traffic control) to evaluate six policies. Public education and information was found to be the most effective policy to increase traffic safety, considering equity. The best equity conscious policies are independent from physical infrastructures, household income level and household location. The proposed framework this paper introduced an innovative distributed architecture based on a wireless sensor network (WSN) with a network coordinator providing remote and ubiquitous authentication module for managing unexpected events.

3. PROPOSED SYSTEM:

This System Consists of a transmitting and a receiving section. Transmitting section has an Arduino Uno micro-controller, Zigbee communicating device, traffic signal and APR9600 Speaker and receiver end has a mobile phone and a Zigbee communication module. This system surveys the purpose of allowing emergency vehicles move faster when the road is blocked. The user will be dialling the road no in which he is on and these signals will be sent to the micro-controller placed in the vicinity of the traffic signal light.

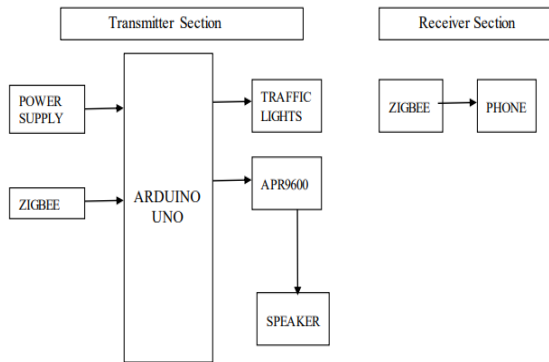

Fig.3.1. Block diagram.

RESULTS:

When the Arduino Uno receives the signals using Zigbee it will be sending signals internally to the traffic lights adjoint to it and accordingly changes the signals of the road from where the signals have been received. A Speaker called as APR9600 will be giving an announcement of the road clearance for emergency purpose so that travellers around are alerted and move aside for the vehicle to proceed. For getting the exact road number where you are, to clear it we use the APP called XCTU where you will be entering the road number those signals are transmitted by wireless Zigbee communication module to the microcontroller ,placed adjacent to the traffic lights. When the following happens there will be transmission of signals from traffic light junction to the speaker and also to the users display pad simultaneously and so the vehicle is moved faster as the traffic gets cleared. The user can have a confirmation of the road clearance approved by the display in his/her display pad that the road has been cleared.

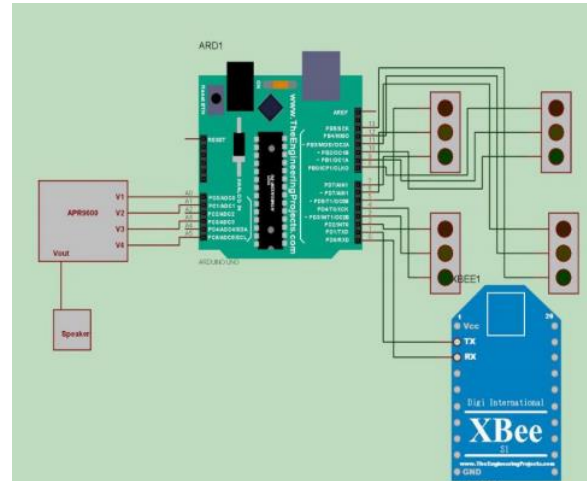

Fig.3.2. Circuit diagram.

The APP is initiated and the road number is entered. Signals are transmitted from the transmitter to the receiver Zigbee which functions according to the instructions which is programmed. Therefore the communication takes place and according allows the Ambulance to pass from one side of junction during an Emergency.

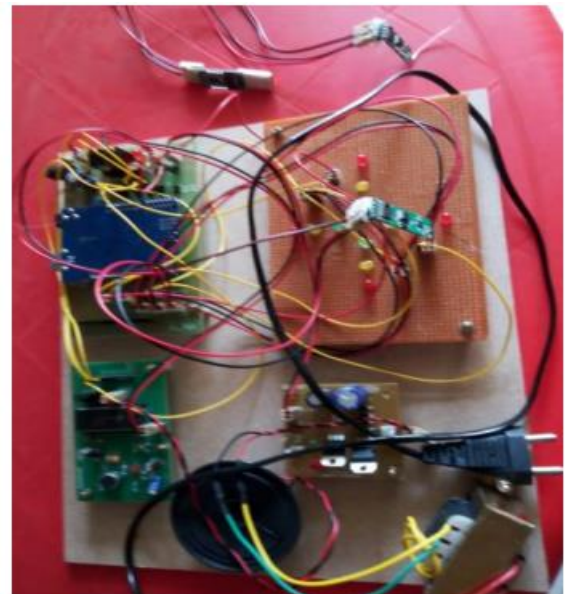

FIG.3.3. Hardware kit image.

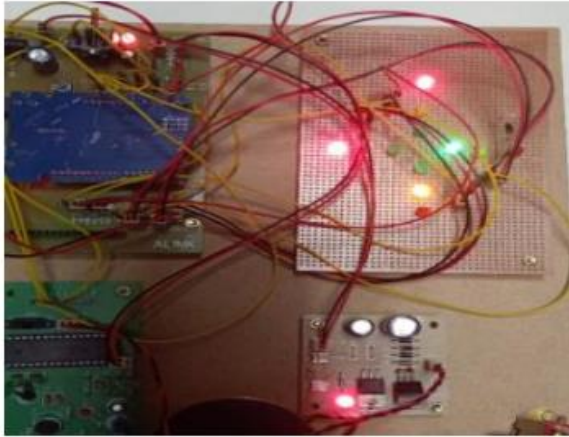

Fig.3.4. OUTPUT results.

4. CONCLUSION:

In the present technology of Emergencies and incidents, we need to maintain Hassel free and easier way avoiding manual traffic thereby saving time. As the increase in technology and living has become fast with many more than a dozen vehicles, the queuing process prevails. To avoid the traffic a model has been studied and prototype. An ambulance is fitted with a zigbee transmitter to transmit signals and traffic signal which has a zigbee receiver controlled by the micro controller when receives signal and accordingly will clear the path for the vehicle to move.

FUTURE SCOPE:

Usage of RFID reader near the traffic signals where a stolen vehicles can be recognized avoiding their further entry. Additionally a major area can be the usage of GPS Signals to make it a real time approachable project, which is inbuilt in phone but we need App/Google device Location shared GPS Enabled Service to know the exact location

of the Mobile but we also need Maps which have to be enabled.

REFERENCES

- [1] A. Sharma, R. Chaki and U. Bhattacharya, Applications of Wireless Sensor Network in Intelligent Traffic System: A Review, Electronics Computer Technology (ICECT), 2011 3rd International Conference on Issue Date: 8-10 April 2011 On page(s): 53-57 Print ISBN: 978-1-4244-8678-6.
- [2] Malik Tubaishat, Qi Qi, Yi Shang and Hongchi Shi, Wireless Sensor-Based Traffic Light Control, IEEE CCNC 2008 Proceedings, 1-4244-1457-1/08.
- [3] C. Abishek, Mukul Kumar and Kumar Padmanabh, City Traffic Congestion Control in Indian Scenario using Wireless Sensors Network, Fifth IEEE Conference on Wireless Communication and Sensor Networks (WCSN) (2009) pp. 1-6.
- [4] Amnesh Goel, Sukanya Ray and Nidhi Chandra, Minimization of Waiting Time in Traffic Signals on Indian Roads Based on Wireless Sensor Network, J. Computing, 3(12) (2011) ISSN 2151-9617.
- [5] Tousif Osman, Shahreen Shahjahan Psyche, J. M. Shafi Ferdous, Hasan Zaman, "Intelligent traffic management system for cross section of roads using computer vision",2017.
- [6] Traffic Congestion in Bangalore—A Rising Concern. [Online]. Available: <http://www.commonfloor.com/guide/trafficcongestion-in-bangalore-arisingconcern-27238.html>, accessed 2013.
- [7] A. K. Mittal and D. Bhandari, "A novel approach to implement green wave system



International Journal For Advanced Research In Science & Technology

A peer reviewed international journal

www.ijarst.in

IJARST

ISSN: 2457-0362

and detection of stolen vehicles,” in Proc. IEEE 3rd Int. Adv. Comput., Feb. 2013, pp. 1055–1059.

[8] S. Sharma, A. Pithora, G. Gupta, M. Goel, and M. Sinha, “Traffic light priority control for emergency vehicle using RFID,” Int. J. Innov. Eng. Technol., vol. 2, no. 2, pp. 363–366, 2013.