

DEVELOPMENT OF PRECISION FARMING USING MODULAR MULTI NODE SENSOR

*Syed Asrar Uddin¹, Shaik Arbaz², Syed Ashraf Ahmed³, Syed Sultan Mahmood⁴,
Zubeda begum⁵*

1, 2, 3 UG students, Department of ECE, ISL ENGINEERING COLLEGE, Bandlaguda,
Chandrayangutta, Hyderabad, Telangana, India-500005.

^{4,5}Asistant Professor, Department of ECE, ISL ENGINEERING COLLEGE, Bandlaguda,
Chandrayangutta, Hyderabad, Telangana, India-500005.

ABSTRACT:

The water resource for farming is very much important. In Olden days people used to supply water for irrigation through rivers, reservoirs, tanks, and wells for irrigation farming. Day by day some of such resources vanish and over the century, the population of India has become three times. Demand for food as growing population and the need for water for agricultural productivity is crucial. As a result of a severe shortage of water exists across parts of India. Though we have different solutions with which water and fertilizer utilization can be optimized still there are few gaps which need to be addressed to make the current systems more robust and backed by technology to get better yields. In this work, IoT based water conservation for farming using auomated drip irrigation system by considering scalability. Here for storing statics or parameters could storage is used. Based on these parameters dripping decisions (soil, moisture, and climate conditions) has been taken. The proposed solution is implemented and shown results with necessary parameter.

Keywords: *Soil moisture sensor, Temperature sensor, IOT.*

1. INTRODUCTION:

Water plays a key role in the world in each domain. The population is increasing exponentially, and water conservation is also becoming more and more. Water usage is high in farming fields. Many techniques are introduced to use water in an efficient way for farming. As the world is entering new technologies, it's a mandatory or primary goal to trend up in agriculture [3][4] irrigation in India. Several kinds of research are being done in the sphere of agriculture. Most of the implementations came to signify the utilization of wireless sensing elements in networks to collect the information from totally different sensors which are deployed at varied nodes and send the sensing data through the wireless data transfer protocol. The information obtained from sensors gives knowledge regarding the assorted environmental and other influential factors. Watching those environmental parameter factors isn't

the entire answer to extend the yield of crops to get better results. There is a range of different parameter factors that decrease the outcome to a bigger extent. Thus, automation should be enforced in agriculture to overcome these issues. So, to supply an answer to any or all such issues, it is required to develop an associated integrated system which can watch out of all factors touching the outcome in each stage. However, entire automation in agriculture isn't achieved and thanks to varied problems. Though it's enforced within the analysis level, it's not given to the farming people as a product to urge advantages from such resources. Thus, this paper is to develop good agriculture based on IoT and given to the farming people. During this project, IoT technology helps in collecting data regarding conditions like temperature, water-level, and wetness microcontroller [4][5][7]. IoT leverages farmers to urge connected

to his farm from anyplace and anytime. Agricultural crop watching and management is done using Arduino Uno. Wireless sensing element networks are used for watching the farm conditions and small management areas are accustomed to control and alter the farm processes.

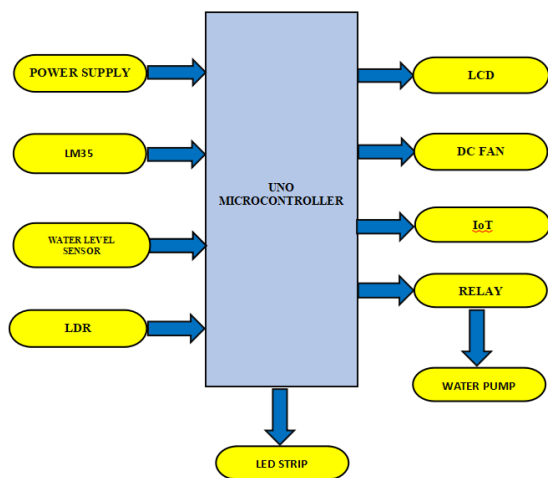

2. PREVIOUS STUDY:

Agriculture plays a important role in all part of the India. Due to sudden change in climate and lower rainfall in all over India, the scope of agriculture become down. Without wasting the water, cultivation should yield

maximum. In traditional method, the land get irrigated with excess amount of water than the crop needs. The wastage of excess water can be overcome by modern irrigation system such as drip irrigation, sprinkle irrigation etc. But this smart irrigation system can overcome the wastage of excess water through manual operation ie., offers a flawless operation in irrigating the land. The design and implementation of a clever irrigation gadget were broadly settled in different situations and most reliable price performance on the electric gadget. In reality, the clever irrigation device has extra benefits than the conventional techniques of irrigation. It uses helpful technology and assists the farmers, to irrigate and feed the crops with correct quantity of water and needed fertilizers to the crops. The implementation of a sensible irrigation system in a very land is simple and therefore the value to put in is additionally less. In this



system we need of soil sensors, according to the size of the agriculture land. With the various soil sensors reading, the land can be irrigated equally by avoiding the problems like wastage of water and unequal irrigation. Equally irrigated land are monitored and controlled by remote operating system. The various mode of operations can be achieved through the android mobile application. It has microcontroller, and a bi-directional communication link. IoT plays a important role for the communicating the system and farmers. The user interface is provided to them by the utilization of Android Mobile Application. The most contribution of this paper is to develop hardware and software for the farmer's irrigation system. The Proposed system of this paper is to eliminate the manual operation and to implement an entire automatic irrigation system. This system requires additional sensors with respect to the size of the farmer's

land. By the implementation of this system, the farmers can able to know about their crops health in all seasons by login with their respective user id into the mobile app to check the status of their irrigation system. In case of power cut, the system can connect to a mini up because the system consumes only less power or once the power reconnects, the system will automatically connects to the Wi-Fi and starts operating automatically. The values from the sensors are sent to the microcontroller. The microcontroller will send this information to the cloud which is connected to the mobile app. After comparing the values with the reference values, the error signal is generated which is sent to the mobile app and the webpage. Through this, the farmers can check the status of the irrigation system remotely by proper checking the volume of water and quantity of fertilizers that are really required by the crops by utilizing this

system, the farmers can yield a most quantity of product with low quantity of investment, water and fertilizers.

3. LITERATURE SURVEY:

This paper related work has done uniquely by two different ways, for example, one is physically and the alternate one is either mechanically or semi mechanically. The smart way systems embody IoT and the normal system. Name itself says IoT described project[1] has been introduced to irrigate the field by fully automatic by using gsm. The GSM module is used to control the irrigation system by sending text messages and alert messages from the module for a flood control system. Then, it is overcome by [2] consists of a water flow level sensor which is used to measure and monitor the flow level of water in the drip irrigation pipe lines to minimize the excess of water by enhancing the plant growth. But for wheat and paddy fields always

having excess of water in the field. Nitrogen in percolation water is used in paddy and wheat fields' soil to predict rice and wheat rotation. And another take a advantage for this one by detect a disease in nutrient growth and how far its growth rate [3] such other things will be same as that of[2]. Someone developed in more way as mobile app by integrated with IoT to monitor and controlling the irrigation [4].The system developed by [5] will not notify the required amount of fertilizer to the farmer. Mobile app is not provided for the framers for ease of use. The developed system [6] requires human power to irrigate the garden and it will not notify the farmer with proper notifications about the crops or plants. [7] has interfaced the sensors with the microcontroller with wireless communication. If the sensor disconnects due to power failure, again it cannot connect to the system automatically. In order to control the usage of water resources

for irrigation, this [8] proposes the design of an automated organic irrigation system in controlling and properly allocating the available water resources for the irrigation system and available electricity for the use of the pump. It deals with the overview of the smart irrigation software development[9]. [10] Deals with the smart irrigation system with microcontroller is integrated with raspberry pi to transfer the data. It also deals with the smart irrigation system [11] with water efficiency to reduce wastage of water.[12] Is also same but its disadvantage is fully manually controlled system. [13] Involves a wireless short distance mesh network to collect the sensor parameters to make a decision for the irrigation system development. The mesh network consists of Xbee module which is used to transfer data in the means of radio frequency. The Xbee in module provides only a short distance network transmission since

there is no proficiency for satellite network system. The fuzzy logic is complicated than our system and this system requires more manual operations [14]. Here the systems are connected with lan network so it requires long cables to transmit the data from the field to the controller. And this system will not notify or indicate any operation to the farmer [15].

4. PROPOSED SYSTEM

First, the system consists of following parts i.e. a microcontroller, relay, soil moisture sensor (LM393), I2C LCD display(16x2), Water pump and Water Level Sensor. A pipe is connected to the water pump in the water tank, which has a water level sensor attached to it, to check the amount of water left in the tank at every moment. The Water pump is connected to the Relay, operated on A.C supply, which turns ON/OFF as

per the data sent by microcontroller by reading the moisture on the soil.

The moisture sensor is dipped under the ground near the plants. The sensor is always ON and senses the moisture content and sends the data to the controller which in exploits it to the LCD for displaying the data. Whenever the moisture content goes down, as per the crop farmer grows, the specified value; the Sprinkler starts to sprinkle the water to the field. We are using a servo motor to make a Sprinkler to perform back and forth motion.

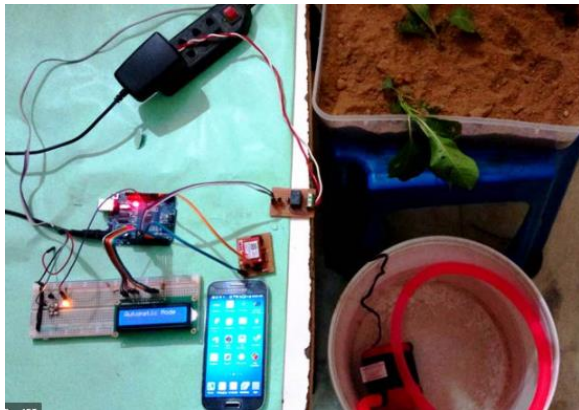

The controller used here is Arduino. Arduino is chosen as it is widely used for research purposes and different

sensors and hardware are easy to interface. The soil moisture/humidity sensor uses 0.4 mA of current so chance of loading effect is very less. All the sensors are be operated by a +9V D.C supply. The LCD is connected to the controller via usual connections with 15th and 16th pins are given +9V and ground connection for backlighting which is useful for viewing in low light. The display shows moisture content is percentage as programmed. The code is written so that it can collect data from a certain server address and send data to it.

4. CONCLUSION:

In today's world, the accidents due to drunken drive and rash driving cause a great damage to the lives of common people. Even though, the government passes many bills and laws to minimise and control the accidents done under the influence of alcohol. But it is not effective.

However, the proposed system could minimise and control the accidents made due to drunken and drive. This system continuously monitors the alcohol level consumed by the driver and when, it attains the maximum threshold value then the system stops the ignition system of the vehicle preventing the accidents. Moreover, it also monitors the heart beat rate of the driver frequently. The sensor readings are updated in the cloud from time to time through IoT. Even if the driver tries to escape after committing the accident, the readings in the cloud will act as a major evidence for the police to punish the culprit.

REFERENCES:

1. R.Suresh, S.Gopinath, K.Govindaraju, T.Devika, N.SuthanthiraVanitha, "GSM based Automated Irrigation Control using Raingun Irrigation System", International Journal of Advanced Research in Computer and Communication Engineering Vol. 3, Issue 2, February 2014.
2. Pavithra D.S, M. S .Srinath, "GSM based Automatic Irrigation Control System for Efficient Use of Resources and Crop Planning by Using an Android Mobile", IOSR Journal of Mechanical and Civil Engineering (IOSR-JMCE) Vol 11, Issue I, Jul-Aug 2014, pp 49-55.
3. LaxmiShabadi, NandiniPatil, Nikita. M, Shruti. J, Smitha. P&Swati. C, "Irrigation Control System Using Android and GSM for Efficient Use of Water and Power", International Journal of Advanced Research in Computer Science and Software Engineering, Volume 4, Issue 7, July 2014.
4. Shiraz Pasha B.R., Dr. B Yogesha, "Microcontroller Based Automated Irrigation System", The International Journal Of Engineering And Science (IJES), Volume3, Issue 7, pp 06-09, June 2014.



5. S. R. Kumbhar, Arjun P. Ghatule, “Microcontroller based Controlled Irrigation System for Plantation”, Proceedings of the International MultiConference of Engineers and Computer Scientists 2013 Volume II, March 2013.
6. Yunseop (James) Kim, Member, IEEE, Robert G. Evans, and William M. Iversen, “Remote Sensing and Control of an Irrigation System Using a Distributed Wireless Sensor Network”, IEEE TRANSACTIONS ON INSTRUMENTATION AND MEASUREMENT, Volume 57, Number 7, JULY 2008.
7. Venkata Naga RohitGunturi, “Micro Controller Based Automatic Plant Irrigation System”, International Journal of Advancements in Research & Technology, Volume 2, Issue4, April-2013.
8. MahirDursun and SemihOzden, “A wireless application of drip irrigation automation supported by soil moisture sensors”, Scientific Research and Essays, Volume 6(7), pp. 1573-1582, 4 April, 2011.
9. S. Harishankar, R. Sathish Kumar, Sudharsan K.P, U. Vignesh and T.Viveknath, “Solar Powered Smart Irrigation System”, Advance in Electronic and Electric Engineering, Volume 4, Number 4 (2014), pp. 341-346.
10. AgriSETA, Sector Analysis agriculture, Department of Higher Education and Training, South Africa, 2010
11. Cousins, B., What is a smallholder? Class analytic perspectives on small-scale farming and agrarian reform in South Africa, <http://www.plaas.org.za/pub2/downloads/wp16/>
12. Milimo, J.T., Shilito, T., Brock, K., The poor of Zambia speaks, Zambia Social Investment Fund, <http://www.worldbank.org/afr/wps/wp85.pdf>, 2000
13. National Department of agriculture,



<http://www.nda.agric.za/docs/GenPub>

/DevStrat2007.pdf, 2007

14. Rouhani, Q.A., Brits, P.J., Report
WRC: TT235/04, Rhodes University,
2004 15. Siegel, P.B., Poverty
reducing potential of small-holder
agriculture in Zambia: dualism and
dualism within dualism, PVA
Consultation workshop, Lusaka, 2005.