



DESIGN AND ANALYSIS OF ACCUMULATOR

1 V.K.SIVAKUMAR ADAPA, 2 N.BALA KRISHNA

1 Student, 2 Asst. Professor

1, 2 NOVA COLLEGE OF ENGINEERING & TECHNOLOGY

ABSTRACT: Pressure transient can occur in piping system due to much different abnormal system conditions. In a hydraulic system, one such condition that can cause a pressure transient is the action of an external force on an actuator in the system. An example where this type of transient can occur is in mechanical shocks of hydraulically operated suspension system for a dump truck. A proven method to suppress this type of pressure transient is to incorporate an accumulator into the system near the actuator. This project outlines a numerical approach for analyzing the response of such an accumulator affected by external force acting on a hydraulic actuator. A description is presented on how to perform fundamental analyses of accumulators used to maintain pressure control in closed-loop fluid systems since the accumulator is one of the most important components with the largest sound radiation surface area. In rotary compressor, its noise contribution may be substantial. Noise generation and transfer mechanism of the accumulator are so complicated that it is difficult to identify the acoustic characteristics, because both structural and cavity modes are possible to be excited by many sources such as structural vibration, aero-acoustic pressure pulsation etc., in addition coupling between them cannot be ignored either. In this paper, both of the noise generation and transfer mechanisms are studied systematically, also standing wave and mechanical vibration theory are applied to build the mathematical model.

Key words: CATIA software, ANSYS software

INTRODUCTION

All energetic systems, whether they are mechanical, electric, hydraulic, or some combination can be expressed in terms of effort and flow. The power transferred from

one energetic element to the next is always a product of these two elements, force and velocity, voltage and current, pressure and volumetric flow rate. Since energy is the time integral of power, energy transfer can simply be measured as the integral of this

product over time. The relationship between effort and flow is a reactionary one, governed by the properties of each system element. For potential energy storage elements, this relationship is an algebraic function between effort and the integral of flow, force and displacement for springs, voltage and charge for capacitors, pressure and volume change for hydraulic accumulators. Just as spring constants dictate the force displacement relationship of springs, bulk modulus—the inverse of compressibility—dictates the relationship between pressure and volume change in hydraulic accumulators. Since hydraulic fluid itself has a very high bulk modulus, miniscule changes in the volume of a closed hydraulic system result in large swings in pressure. Pump-motor noise can cause unsafe pressure fluctuations in this way if unaccounted.

needed. They are useful tools for improving hydraulic efficiency. Industrial accumulators are classified as hydro pneumatic. This type of accumulator applies a force to a fluid by the use of compressed gas. The two most common types of accumulators are the rubber bladder type and the piston accumulator. Below will be presented the accumulators rubber bladder type. The rubber bladder is compressed when the fluid under pressure is supplied to the hydraulic accumulators and the gas and oil pressure increases. Conversely, when accumulator supplies oil to the hydraulic system, the oil pressure drops and the rubber bladder expands. Whenever additional oil is required by the system, it is supplied by the accumulator even as the pressure in the system drops by a corresponding amount.

Hydraulic system to:

- cope with extremes of demand using a less powerful pump
- store power for intermittent duty cycles
- provide emergency or standby power
- respond more quickly to a temporary demand

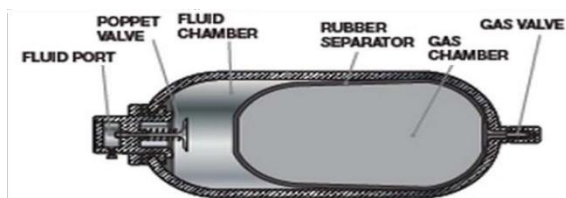

History of hydraulic accumulators

Hydraulic accumulators have the ability to store excess energy and release it when

- smooth out pulsations
- Compensate for leakage loss.

- Mining Machinery & Equipment
- Mobile & Construction Equipment
- Off- Road Equipment.

Types of Hydraulic Accumulators

- Piston type accumulator
- Bladder type accumulator
- Diaphragm type accumulator
- Spring type accumulator

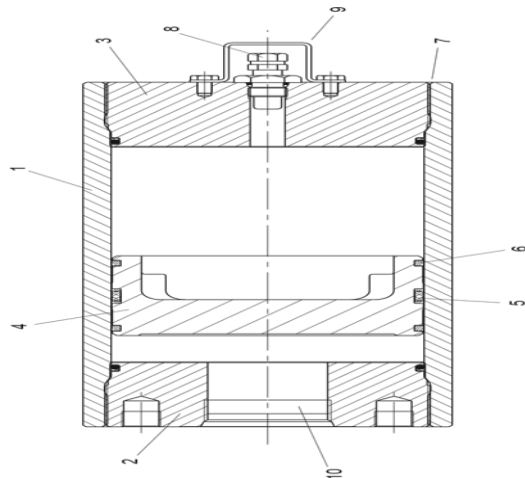

Applications

Some common applications of bladder accumulators are:

- Agricultural Machinery & Equipment
- Forestry Equipment
- Oil Field & Offshore
- Machine Tools
- Mining Machinery & Equipment
- Mobile & Construction Equipment
- Off- Road Equipment.
- NBR (Standard Nitrile)
- LT-NBR (Low Temperature Nitrile)
- ECO (Epichlorohydrin)
- IIR (Butyl)
- FPM (Fluor elastomer)
- others (available upon request)

Construction

Both types of diaphragm accumulators have the same basic construction. The difference is in the shell. The welded version has a shell that is electron-beam welded, and therefore cannot be repaired. The threaded type has a shell made up of two halves (top and bottom) which are held together by a threaded locking ring.

Diaphragm Materials

Not all fluids are compatible with every elastomer at all temperatures. Therefore, the following choice of elastomers:

Corrosion Protection



For use with certain aggressive or corrosive fluids, or in a corrosive environment, the protective coatings and corrosive resistant materials (i.e. stainless steel) for the accumulator parts that come in contact with the fluid, or are exposed to the hostile environment.

Mounting Position

Diaphragm accumulators by design may be mounted in any position. In systems where contamination is a problem, we recommend a vertical mount with fluid port oriented downward.

System Mounting

The diaphragm accumulators are designed to be screwed directly onto the system. We also recommend the use of our mounting components, which are detailed below, to minimize risk of failure due to system vibrations.

Capacity

Accumulator volumetric capacity the default value is 0.008 m^3 .

Preload pressure (gauge)

Pressure at which fluid starts entering the chamber the default value is $1e6 \text{ Pa}$.

Maximum pressure

Pressure at which the accumulator is fully charged the default value is $3e6 \text{ Pa}$.

Literature Survey

Zainol (1990) have reported that the major problem of back pressure vessel was the loss of steam of about 27 to 50% to the atmosphere. This is due to its design and size which are not specific for accumulating and controlling the steam distribution to the sterilizers and factory heating. Its function is more as a temporarily steam storage vessel for maintaining the turbine performance. The practice of venting off steam from the back pressure vessel to atmosphere over a certain minimum time is inevitable when the accumulation of steam in the back pressure vessel exceeds the relief valve set point (around 45 psi). Consequently, there is a deficit in steam supply to the sterilizers, resulting in fresh fruit bunches not being fully sterilized. Mustafa (1994) have identified three major types of disturbances that led to the severe steam fluctuations in steam supply and demand. The most critical

type is random steam fluctuations in boiler, steam turbine, back pressure and sterilizers resulting in steam venting or time delay. The next disturbance is variation of boiler pressure due to inconsistent fuel quality which affects all units downstream and the last type is random steam injection in palm oil stream such as digester to maintain temperature and flow.

Introduction to CAD

Computer-aided design (CAD), also known as computer-aided design and drafting (CADD), is the use of computer technology for the process of design and design-documentation. Computer Aided Drafting describes the process of drafting with a computer. CADD software, or environments, provides the user with input-tools for the purpose of streamlining design processes; drafting, documentation, and manufacturing processes. CADD output is often in the form of electronic files for print or machining operations. The development of CADD-based software is in direct correlation with the processes it seeks to economize; industry-based software (construction, manufacturing, etc.) typically uses vector-based (linear) environments

whereas graphic-based software utilizes raster-based (pixilated) environments.

Different parts of diaphragm accumulator

1. Bottom cover
2. Top cover
3. Diaphragm
4. Diaphragm plug

A 2D drawing is used to design a 3D model for our component using Catia software. Below shows the 2D drawings of the diaphragm accumulator with all the required dimensions and GD&T representations the suits the best for manufacturing the component without any errors.

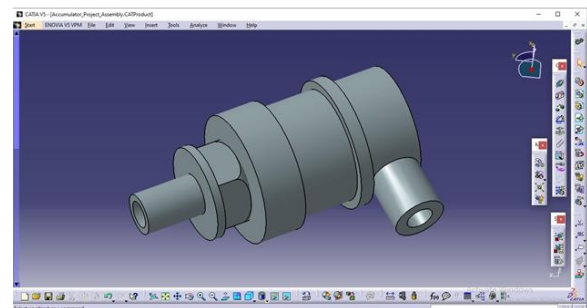

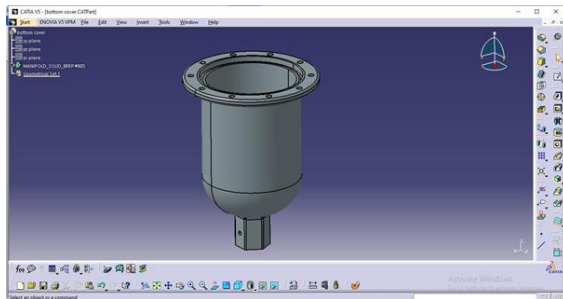
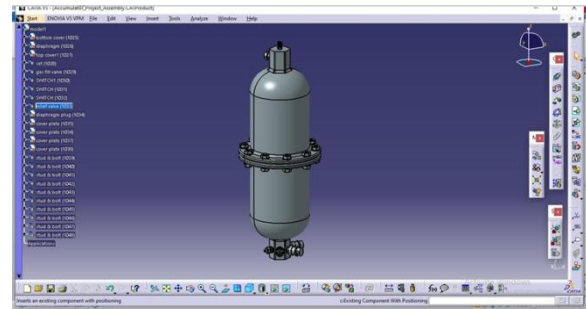
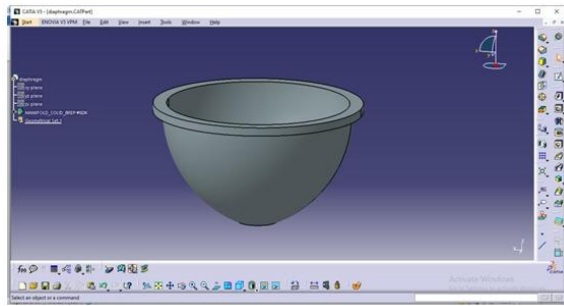

MESHING OF A DIAPHRAGM ACCUMULATOR

Meshed parts of the diaphragm accumulator in Hyper mesh

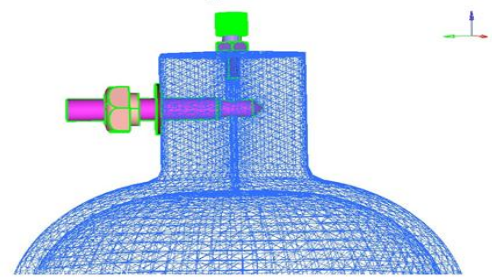
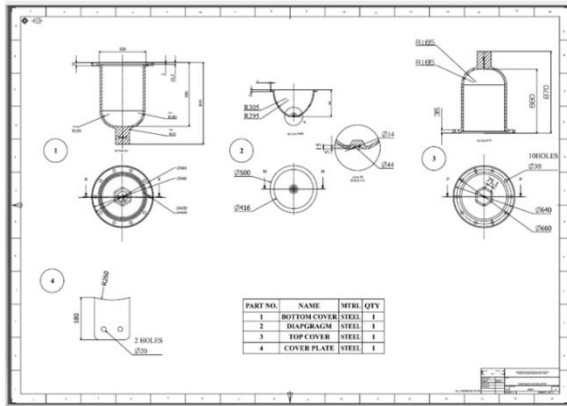

Figure 19: Top Cover mesh

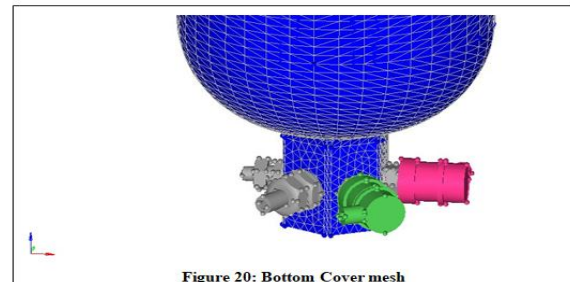
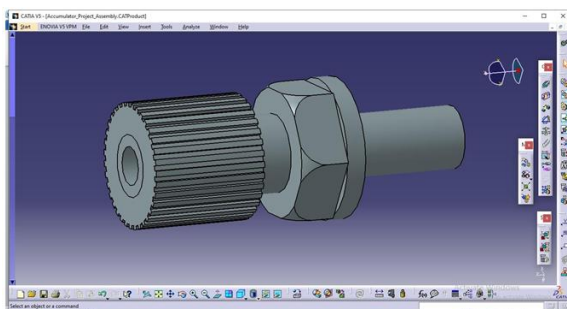
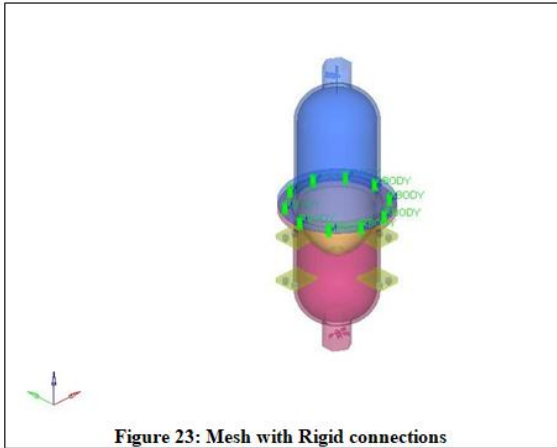
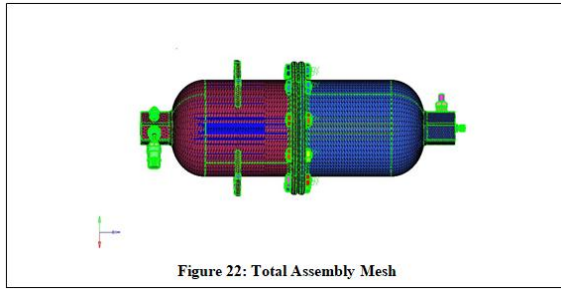
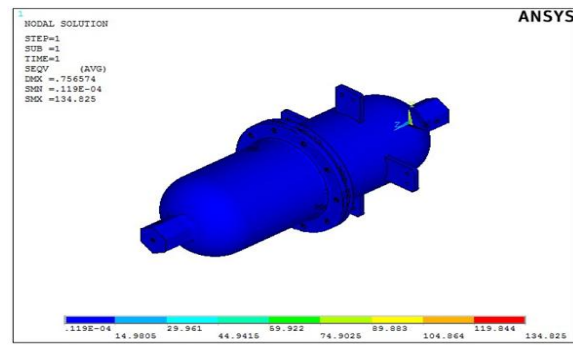
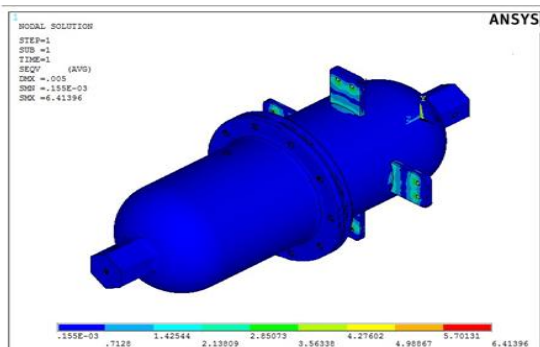
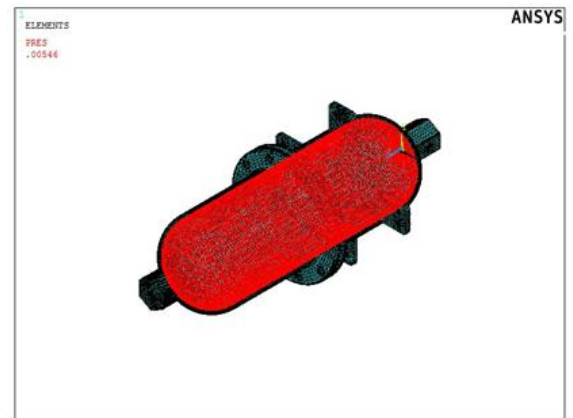
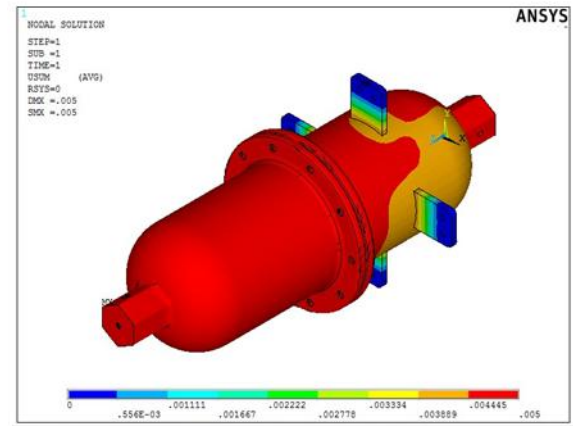

Figure 20: Bottom Cover mesh





Pre-processing phase	Solution Phase	Post-processing Phase
1. Geometry definitions	1. Element matrix Formation	1. post solution Operation
2. mesh generation	2. Overall matrix triangulation	2. Post data printout
3.constraint & load definitions	3. Displacement, stress, etc. calculation	3. Postdate scanning
4. Model displays		4. post data display
5. material definitions		



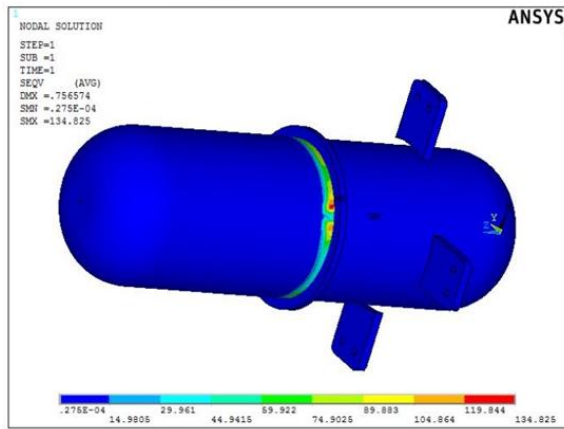

Figure 28: Internal stress plot

Sno	Analysis	Stress (N/mm ²)	Displacement (mm)	Allowable Stress (N/mm ²)
1	Self-weight analysis	6.4	0.005	250
2	Pressure analysis	135	0.7	250

Conclusion

Based on the Analysis results, the designed Bladded type Accumulator is safe for the applied internal pressure. The initial natural frequency is 85 Hz, which indicates the robust structure for avoiding vibrations. The design has the following advantages for working prototype. Lower installed system costs, accumulator assisted hydraulics can reduce the size of the pump and electric motor which results in a smaller amount of oil used, a smaller reservoir and reduced equipment costs.

Less leakages and maintenance costs, the ability to reduce system shocks will prolong component life, reduce leakage from pipe joints and minimize hydraulic system maintenance costs. Improved performance, low inertia bladder accumulators can provide instantaneous response time to meet peak flow requirements. They can also help to achieve constant pressure in system using variable displacement pumps for improved productivity and quality. Reduced noise levels, reduced pump and motor size couple with system shock absorption overall

Modal analysis

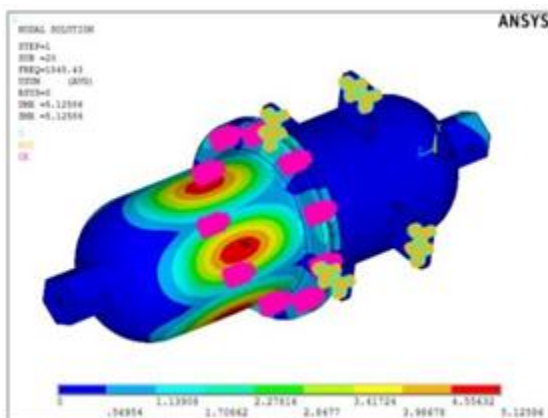
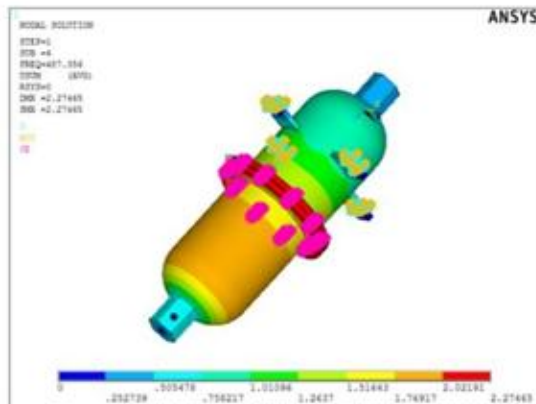



machine sound levels and result in higher operator productivity.

Bibliography

1. Strength of Materials
(Ramamrutham)
2. Engineering Mechanics
(Bhavakatti&Pakirappa)
3. <https://En.Wikipedia.Org/Wiki/Steel>
4. https://En.Wikipedia.Org/Wiki/Hydraulic_Accumulator
5. https://En.Wikipedia.Org/Wiki/List_Of_Materials_Properties#Mechanical_Properties
6. <http://Dta.Eu/Hydraulics/Hydraulic-Accumulators/>
7. Hydraulic Accumulator (Prembaboo)