

**SMART CRADLE SYSTEM FOR BABY USING ESP8266**Mr. N Ramesh Babu ¹, Mr. K Sanjeeva Rao ²^{1,2}Assistant Professor, Dept. Of ECE, A.M.Reddy Memorial College of Engineering and Technology, Narasaraopet**ABSTRACT**

The smart cradle system for baby monitoring system gives a reliable and efficient baby monitor that can play a vital role in providing better care and protection for any infant. Parents of today's generation are often busy in their professional life. This demands a requirement to develop a new low cost indigenous infant safety system based smart cradle system. Since existing cradles are very expensive, this project presents the design and implementation of a low cost Infant Safety Baby's Cradle System. This paper presents the design of Baby Monitoring smart cradle system using ESP8266. This system architecture consists of sensors for monitoring vital parameters such as baby bed wet condition, baby crying monitoring and cradle controlling.

The baby cradle is generally used to sleep babies in comfort. Babies feel soothe in the cradle that is why is most necessary for babies. But swinging of baby cradle manually it needs human being. In today's life everyone is busy in their work, but baby care is very necessary as well. In recent development automation is introduced in everywhere as there are so many technologies available.

The baby cradle also needs to be an automated system. In this regards there are so many literatures are available on baby cradle automation and baby monitoring system. The Arduino based baby monitoring system is presented in some literature where baby crying, wet sensing when baby excretes, baby crying alarm is presented. Another development is to sense various biological parameters of the baby like temperature and alerting baby mother for necessary action.

INTRODUCTION

The IoT Smart Cradle for Baby is an innovative solution designed to provide a safe and nurturing environment for infants. This intelligent cradle integrates various sensors and actuators to monitor and respond to the baby's needs, ensuring their comfort and safety. The cradle is equipped with sensors to track moisture in baby's bed, and motion, providing real-time data to parents. This information enables parents to create an optimal environment for their baby, adjusting factors such as providing better bed to promote healthy sleep and development.

In addition to environmental sensors, the cradle features a sound sensor to detect the baby's cries and respond immediately to swing the cradle. This feature helps to calm the baby and promote relaxation, reducing stress and anxiety for both the baby and parents.

The ESP8266 microcontroller at the heart of the Smart Cradle enables Wi-Fi connectivity, allowing parents to remotely monitor their baby's status and receive notifications on their smartphones. This feature provides parents with unparalleled peace of mind, knowing they can check on their baby from anywhere.

The cradle also includes a motorized rocking mechanism to gently soothe the baby. The Smart Cradle sets a new standard of care for infants. By providing a safe, comfortable, and responsive environment, this innovative solution helps to promote healthy development and gives parents the peace of mind they need to care for their precious little ones.

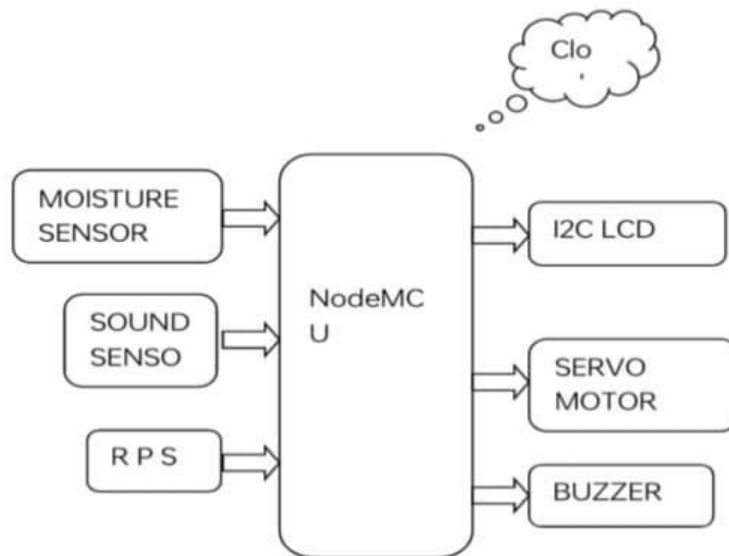

Figure.1 Block Diagram

LITERATURE SURVEY

Traditional baby cradles require manual intervention for rocking and monitoring. With advancements in IoT (Internet of Things) and embedded systems, smart cradles have been developed to provide automation and remote monitoring. The ESP8266 Wi-Fi module plays a crucial role in enabling smart functionalities by allowing wireless communication and control.

Automated Rocking Mechanism

- Traditional cradles require manual effort to rock, leading to fatigue for caregivers.
- Some studies propose using motors (servo, DC, or stepper) controlled by microcontrollers (ESP8266, Arduino, Raspberry Pi) to automate rocking.

IoT-Based Monitoring and Control

- ESP8266-based systems enable real-time monitoring of baby's conditions via mobile applications or web interfaces.

Cry Detection and Response Systems

- Sound sensors are commonly used to detect a baby's cry and trigger an automated response.
- Machine learning models for cry classification are also explored in some studies.

Mobile App and Cloud Connectivity

- Mobile applications (Blynk, Firebase, MQTT-based dashboards) allow real-time control and alerts.

PROPOSED SYSTEM

The smart cradle system using ESP8266 is an IoT-based solution designed to monitor and enhance infant care through real-time sensing, automation, and remote monitoring. The system consists of various interconnected components, including an ESP8266 microcontroller, sensors, actuators. The ESP8266 serves as the central processing unit, collecting data from multiple sensors such as a moisture sensor to ensure a comfortable environment, a sound sensor to detect crying.

When the system detects the baby crying, the ESP8266 processes the signal and triggers automatic responses, such as activating a motor to gently rock the cradle. Parents can access this information through a mobile application or web dashboard, receiving instant notifications in case of abnormal conditions like excessive crying and baby's bed condition.

This smart cradle system ensures enhanced safety, comfort, and convenience for both babies and parents by integrate and remote monitoring, and automated soothing mechanisms.

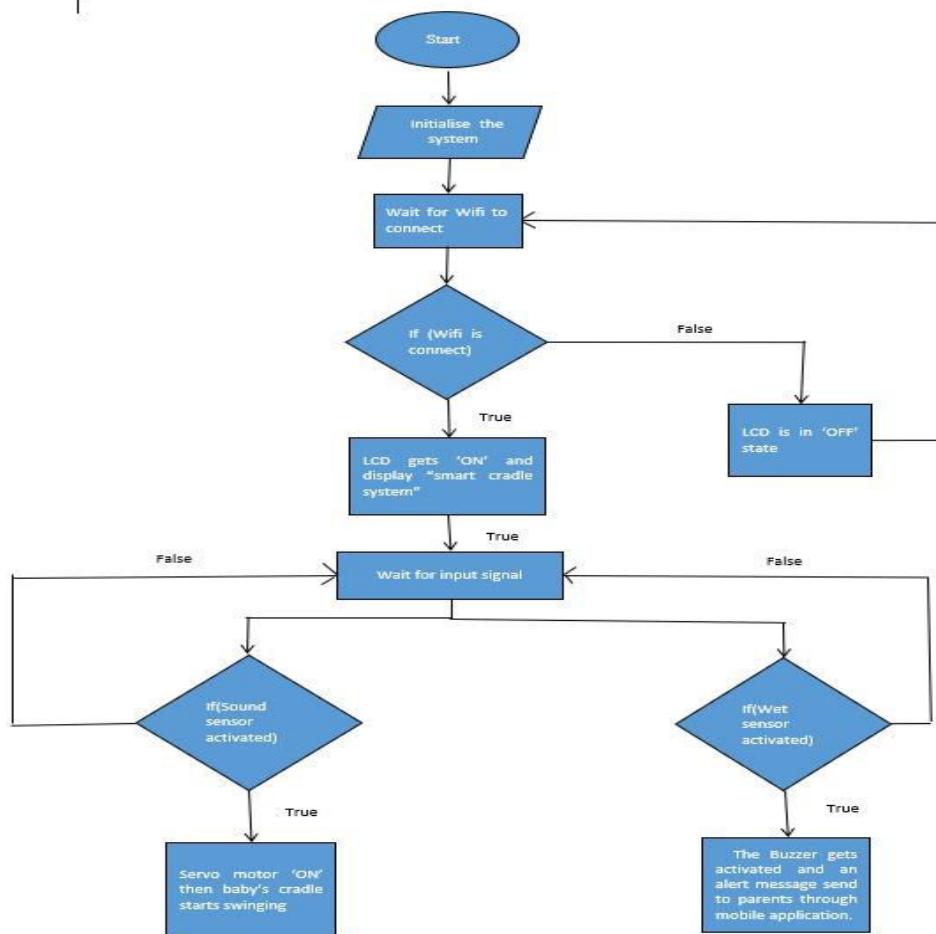

Figure.2 Flow chart

The Smart Cradle System using ESP8266 automates infant care with sensors and IoT connectivity. It includes a moisture sensor to detect wetness and a sound sensor to identify baby cries, triggering a servo motor to rock the cradle. A buzzer and I2C LCD provide alerts, while real-time monitoring via cloud or mobile apps enhances parental convenience. The system reduces manual effort, ensuring comfort and safety for the baby. Programmed using Arduino IDE and Embedded C, it offers scalability for future enhancements.

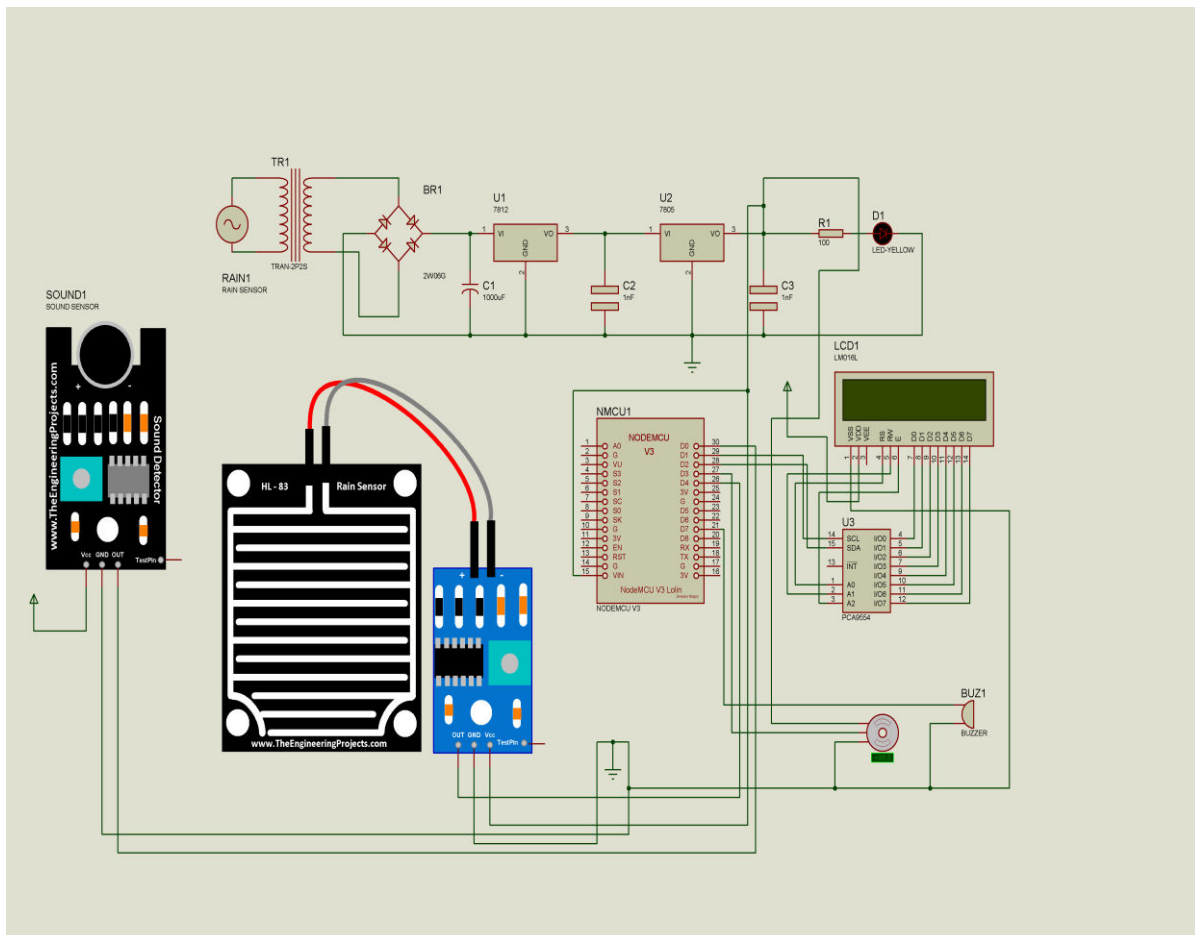

Figure.3 Schematic Diagram

RESULTS

Step 1:

When the sound sensor in the smart cradle system detects the baby's cry, it signals the NodeMCU ESP8266, which activates a servo motor to gently swing the cradle and soothe the baby. The swing's duration and intensity can be adjusted for optimal comfort. If the baby continues to cry despite the automatic rocking, the system can send a cloud-based alert to notify the caregiver. This dual-action system ensures immediate soothing and timely parental intervention for enhanced infant care.

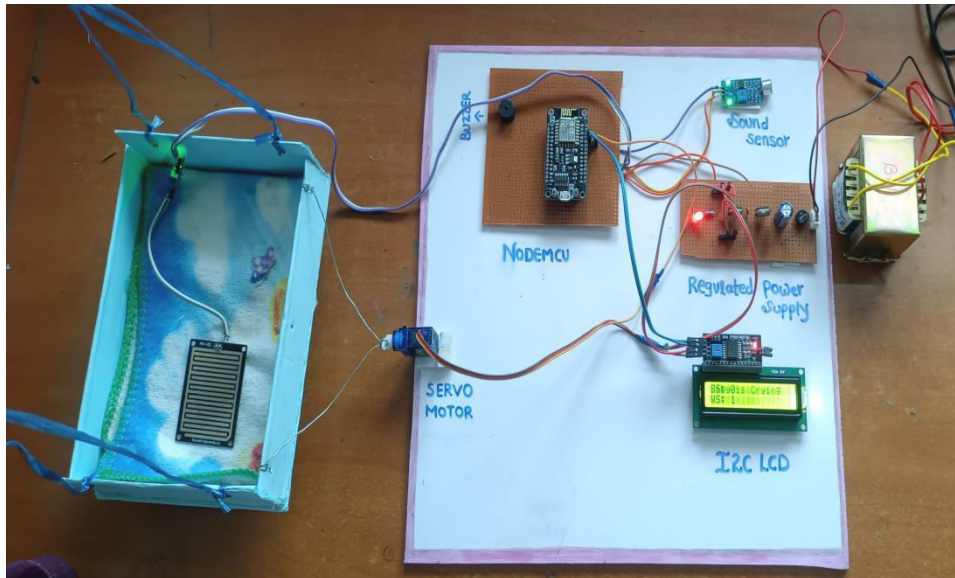

Figure.4 Sound sensor activated

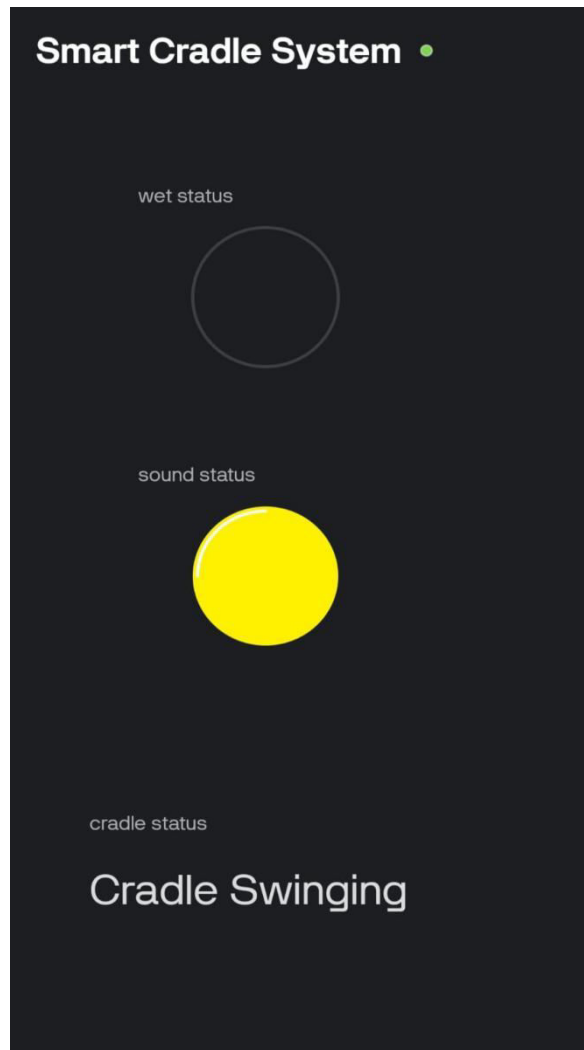

Figure.5 Update in blynk application

Step 2:

When the smart cradle system, the wet sensor detects moisture on the baby's bed and sends a signal to the NodeMCU ESP8266, which activates a buzzer to alert the caregiver. This prompt alert helps ensure the baby's comfort and hygiene by enabling immediate action, such as changing the diaper or cleaning the bed. The system can also send notifications to a connected mobile app, ensuring caregivers are informed even if they are not nearby.

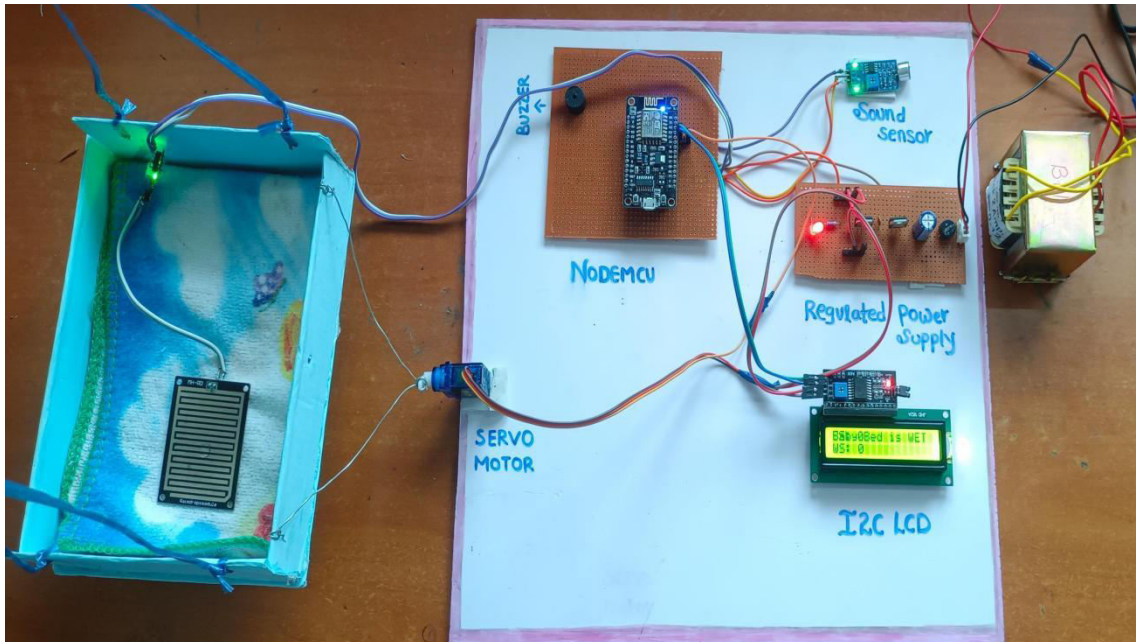

Figure.6moisture sensor activated.



Figure.7Update in blynk application

Step 3:

The smart cradle system operates by integrating multiple sensors and automated controls to enhance infant care. The sound sensor detects the baby's cry and sends a signal to the NodeMCU ESP8266, which activates the servo motor to gently swing the cradle, soothing the baby. Similarly, the wet sensor detects moisture on the baby's bed and signals the microcontroller to activate a buzzer, alerting caregivers to take necessary action. The system can display status updates on an I2C LCD and send real-time alert

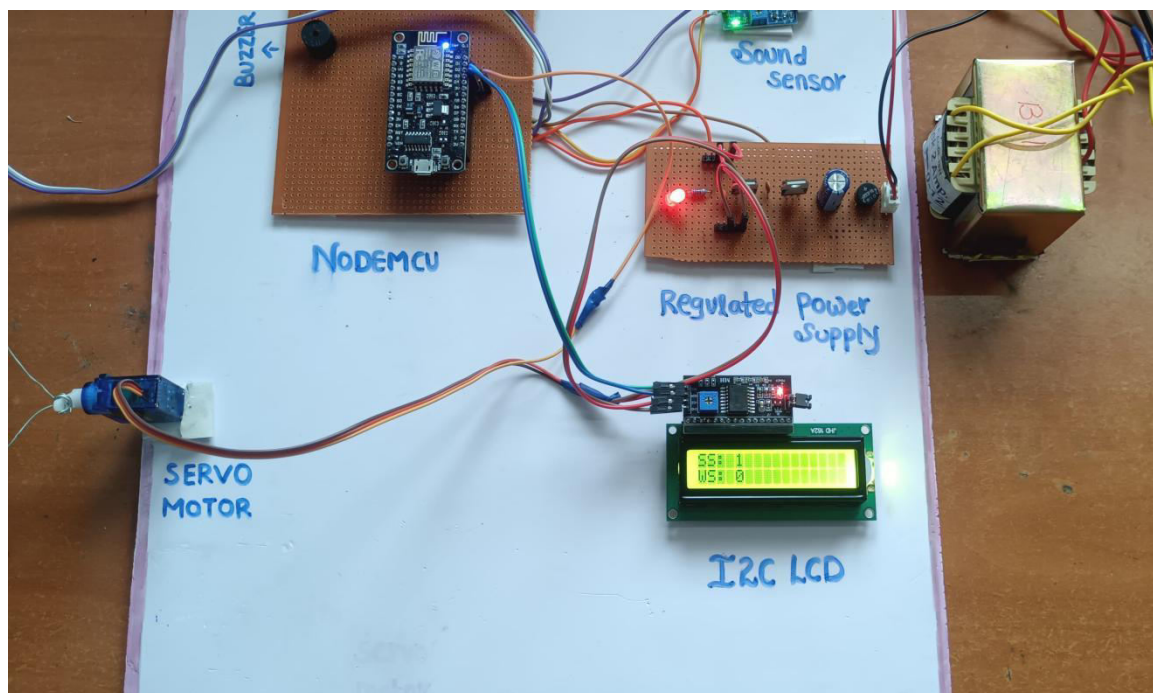

Figure.8 When both sensors activated

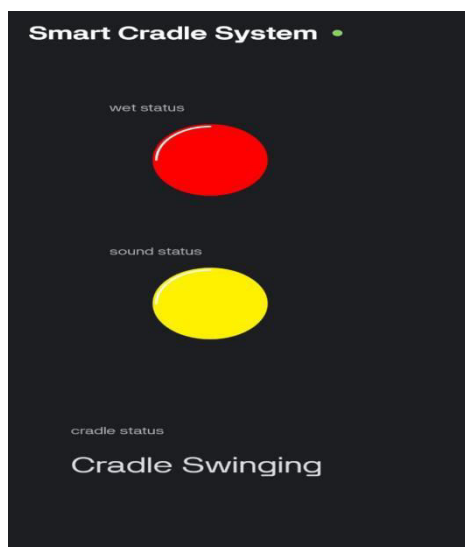

Figure.9 Update in blynk application

ADVANTAGES

- **Automation:** The smart cradle automates baby monitoring and care, reducing the need for constant manual intervention.



- **Real-time Alerts:** With ESP8266's Wi-Fi capability, parents can receive instant alerts about the baby's condition (crying or wetness).
- **Cost-effective:** Designed as a low-cost solution compared to existing expensive automated cradle systems.
- **Enhanced Comfort:** Automatic rocking and environmental monitoring ensure that the baby is comfortable at all times.
- **Remote Monitoring:** Cloud connectivity allows parents to monitor their baby from any location using a smartphone or device.
- **User-friendly Interface:** An I2C LCD display provides clear status updates for easy monitoring.

APPLICATIONS

- **Neonatal Care:** Smart cradles can be used in hospitals to monitor newborns' vital signs, detect potential health issues, and provide a safe and comfortable environment.
- **Pediatric Care:** Smart cradles can be used in pediatric wards to monitor children's health, detect early warning signs of illness, and provide personalized care.
- **Special Needs Care:** Smart cradles can be designed to meet the unique needs of children with special needs, such as autism or cerebral palsy.
- **Infant Monitoring:** Smart cradles can be used at home to monitor infants' sleep patterns, detect potential health issues, and provide parents with peace of mind.
- **Parenting Assistance:** Smart cradles can assist new parents with tasks such as feeding, changing, and soothing their baby.
- **Elderly Care:** Smart cradles can be adapted for use with elderly individuals, providing a safe and comfortable sleeping environment.

CONCLUSION

In conclusion, the IoT Smart Cradle System for Baby using ESP8266 is a revolutionary innovation that has the potential to transform the way we care for infants. By integrating various sensors and actuators, this system provides a safe, comfortable, and nurturing environment for babies to grow and develop. The ESP8266 microcontroller enables Wi-Fi connectivity, allowing parents to remotely monitor their baby's status and receive notifications on their smartphones. The IoT Smart Cradle System has numerous benefits for parents and caregivers. It provides peace of mind knowing that the baby is safe and comfortable, reduces stress and anxiety, and promotes healthy development. The system's ability to detect and respond to the baby's cries, monitor environmental factors, and provide a soothing ambiance makes it an essential tool for infant care.

The IoT Smart Cradle System is also a testament to the power of IoT technology in improving our daily lives. By leveraging the capabilities of the ESP8266 microcontroller, this system demonstrates the potential for IoT to transform various industries, including healthcare. As IoT technology continues to evolve, we can expect to see

more innovative solutions like the IoT Smart Cradle System that improve our lives and the lives of those around us.



FUTURE SCOPE

Expansion and Improvement

The IoT Smart Cradle System for Baby using ESP8266 has a vast future scope, with numerous possibilities for expansion and improvement. One potential area of development is the integration of artificial intelligence (AI) and machine learning (ML) algorithms to enhance the system's ability to detect and respond to the baby's needs. This could include predictive analytics to anticipate the baby's requirements, such as feeding or changing, and automated responses to ensure the baby's comfort and safety.

Additional Sensors and Features

Another area of future scope is the incorporation of additional sensors and features to further enhance the system's capabilities. For example, the integration of a heart rate or oxygen level sensor could provide parents with critical information about their baby's health. Additionally, the inclusion of features such as a built-in baby monitor or a smart feeding system could further expand the system's functionality and value to parents. The system could also be integrated with wearable devices to track the baby's vital signs and provide real-time updates to parents.

Applications Beyond Home Environment

The IoT Smart Cradle System also has potential applications beyond the home environment. For example, the system could be adapted for use in hospitals or healthcare facilities to provide critical care for newborns or premature babies. Additionally, the system's remote monitoring capabilities could be leveraged to enable healthcare professionals to monitor babies remotely, reducing the need for in-person visits and improving health outcomes. This could be particularly beneficial in rural or underserved areas where access to healthcare may be limited.



REFERENCES

1. "Enhanced Baby Monitoring: IoT-driven Smart Cradle System" – This paper discusses the integration of IoT with traditional baby cradles, utilizing the ESP8266 Wi-Fi module for connectivity.
2. "Project Idea | Baby Monitoring Smart Cradle" – An article from GeeksforGeeks presenting a project idea for a baby monitoring smart cradle, highlighting the use of the Raspberry Pi and various sensors.
3. "IOT-Based-Smart-Cradle-using-ESP8266" – A GitHub repository showcasing a smart cradle project that employs the ESP8266, PIR sensor, wet sensor, mic sensor, and servo motor.
4. "Smart Baby Cradle and Monitoring System" – This GitHub project details an IoT-based baby care system designed to automate monitoring and ensure the safety and well-being of infants, utilizing the ESP8266.
5. "IoT-Based Baby Monitoring System for Smart Cradle" – A paper by Babu G., Tina Kishor Lokhande, and Ankita Jagannath Bankar (2020) presenting an IoT-based baby monitoring system specifically designed for smart cradles.
6. "IoT-Based Smart Cradle System for Remote Baby Monitoring" – Authored by P. P. Singh, R. C. Verma, and S. K. Yadav (2022), this paper introduces an IoT-based smart cradle system for remote baby monitoring.
7. "Design and Implementation of an IoT-Based Smart Cradle System for Baby Monitoring" – Authored by V. S. Kumar, Lokaiah Pullagura, and S. Asakipaam (2021), this paper details the design and implementation of an IoT-based smart cradle system for baby monitoring.
8. "IoT-Based Smart Cradle for Baby Monitoring and Entertainment" – S. M. Hasan, M.
9. F. Hossain, and M. A. Hossain (2022) introduce an IoT-based smart cradle that monitors the baby's vital signs and offers entertainment features.