



## A NEW SOLAR PV/FUEL CELL POWERED SRM DRIVE FOR ELECTRIC VEHICLES WITH NOVEL FLEXIBLE ENERGY CONTROL

**B. Imran Khan, M.Tech Student, PVKK Institute of Technology, Anantapur**

**D Mahesh Kumar, Head of the Department, PVKK Institute of Technology, Anantapur**

### ABSTRACT

Because renewable electrical sources are being used as an extra source on circuit configurations, the market for hybrid electrical needs is fast rising. Renewable electrical sources (RES) are proposed as an appealing input in this article. The proposed network used PV cells, fuel cells, and batteries as well as the traditional grid as a source. As a consequence, the supply is more reliable, and the system's efficiency improves. The network is presented in six modes of operation, and the whole circuit is simulated in MATLAB software's power graphical user interface environment, with the results examined using quick fourier transformation analysis.

### I INTRODUCTION

Electric vehicles are automobiles, which are powered by electrical engine and electrical energy. An electric vehicle (EV), also referred to as an electric drive vehicle, uses one or more electric motors or traction motors for propulsion. An electric vehicle may be powered through a collector system by electricity from off-vehicle sources, or may be self contained with a battery or generator to convert fuel to electricity. EVs include road and rail vehicles, surface and underwater vessels, electric aircraft and electric spacecraft. EVs first came into existence in the mid-19th century, when electricity was among the preferred methods for motor vehicle propulsion, providing a level of comfort and ease of operation that could not be achieved by the gasoline cars of the time. The development of electric vehicles is a very important and prospective process. Electric vehicles are powered by an electric motor instead of an internal combustion engine. Electric vehicles are 100% eco-friendly and they do not emit any toxic gases like CO<sub>2</sub>, N<sub>2</sub> etc. which causes Global warming. But there are some

downsides in the case of electric vehicles. Due to the limitation of current battery technologies, the driving range is very short. This will reduce the wide application of electric vehicles. In earlier, in terms of motor drives, high-performance permanentmagnet (PM) machines are widely used[4]. In PM machines there is no field winding and the field is provided by the permanent magnet. Most commonly rare earth materials are used. But they are very costlier. So by the use of PM machines it will also reduce the wide application of electric vehicles. To overcome these issues a photovoltaic panel and a switched reluctance motor can be used for power supply and motor drive [3]. By introducing PV panel on the top of the vehicle, a suitable energy source can be achieved. PV panel has low power density for traction drives; they can be used to charge the batteries. Also the SRM need no rare earth materials.

The switched reluctance motor (SRM) is a type of a stepper motor, an electric motor that runs by reluctance torque [1]. Unlike common DC motor types, power is

delivered to windings in the stator (case) rather than the rotor. This greatly simplifies mechanical design as power does not have to be delivered to a moving part, but it complicates the electrical design as some sort of switching system needs to be used to deliver power to the different windings. With modern electronic devices, precisely timed switching is not a problem, and the SRM is a popular design for modern stepper motors. Its main drawback is torque ripple.

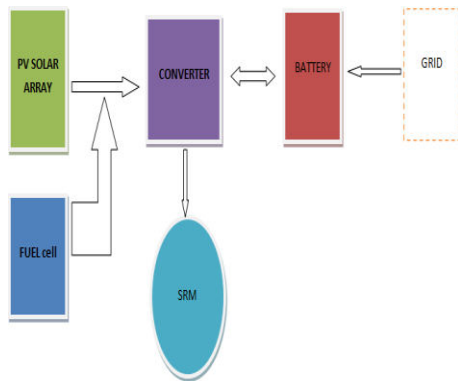

Fig 1 block diagram

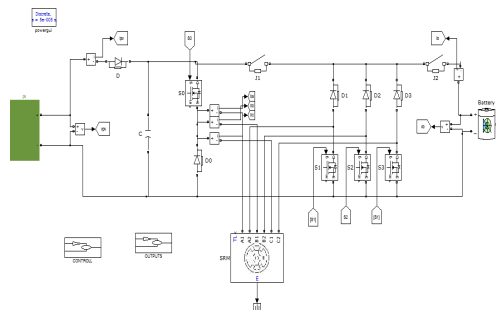

Fig 2 Existing circuit configuration

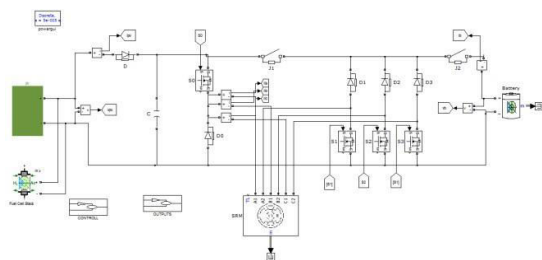

Fig 3 proposed network topology

In order to decrease the energy conversion processes, one approach is to redesign the motor to include some onboard charging functions. The performance of battery modules depends not only on the design of the modules but on how the modules are used and charged as well. In this sense, battery chargers play a critical role in the evolution of this technology [2]. Generally, battery chargers are classified into the following two types: 1) The onboard type and 2) The stand-alone (off board) type. Because the onboard type of chargers should always be carried by the vehicle, the weight and space, as well as the cost, have to be minimized. Thus, it is normally not practical to have a high-power level of the onboard chargers with galvanic isolation. Although isolation is a very favorable option in the charger circuits for safety reasons it is usually avoided due to its cost impact on the system. Off board chargers are located at a fixed location. They are limited in their power output by the ability of the battery to accept the charge. The maximum power point tracking (MPPT) and solar energy utilization are the unique factors for the PV-fed EVs. In order to achieve low-cost and flexible energy flow modes, a low-cost tri-port

converter can be used to coordinate the PV panel, SRM, and battery

## II CIRCUIT OPERATION

Conventional PV fed EV system The renewable energy is vital for today's world as in near future the non-renewable sources that we are using are going to be get exhausted. The solar vehicle is a step in saving the non-renewable sources of

energy. The basic principle of solar car is to use energy that is stored in the battery during and after charging it from a solar panel. The charged batteries are used to drive the motor which serves here as an engine. Energy is one of the most vital needs for human survival on the earth. We are dependent on one form of energy or the other form for fulfilling our needs.

The above diagram gives an overview of the working of solar vehicle. Sun is the main source of energy for the vehicle. Energy from Sun is captured by the solar panels and is converted to electrical energy. The electrical energy thus formed is being fed to the batteries that get charged and is used to run 24 V DC high torques DC series motor. The shaft of the motor is connected to the rear wheel of the vehicle through chain sprocket. The batteries are initially fully charged and thereafter they are charged by panels. This helps in completing the charging-discharging cycle of the batteries, which is very important for proper working of batteries. DC motors were the preferred option in variable-speed operation applications before the development of advanced power electronics. The main disadvantages are low power density compared with alternative technologies, costly maintenance of the coal brushes (about every 3000 h), and low efficiency, although efficiency values over 85% are feasible. DC motors still have a wide market of lower and middle power range commutation vehicles. In earlier, in terms of motor drives, high-performance permanent-magnet (PM) machines are widely used. In PM machines there is no field winding and the field is provided by the permanent magnet. Most commonly rare earth materials are used. But they are

very costlier. So by the use of PM machines it will also reduce the wide application of electric vehicles

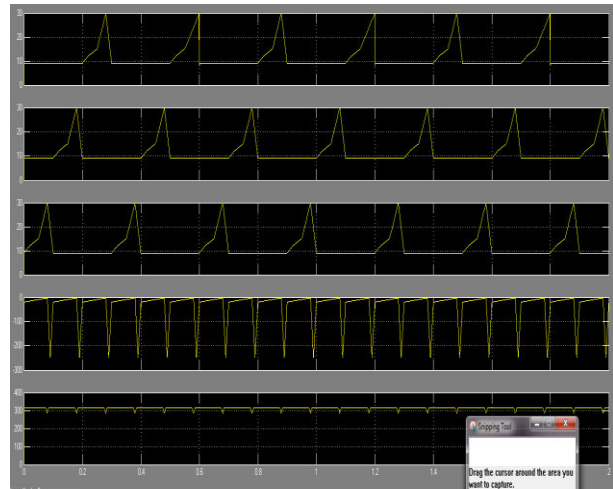

Simulation results of driving-charging mode (mode 1)

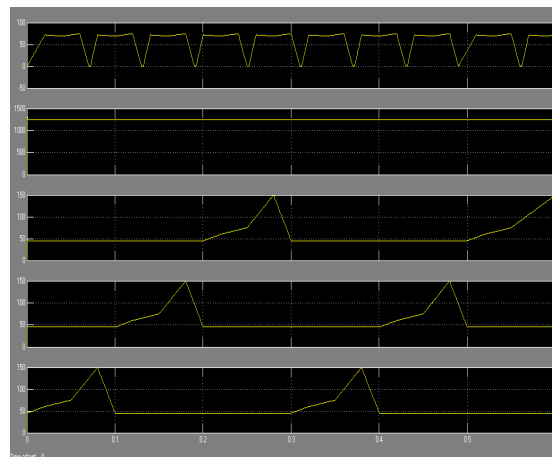

Simulation results of single-source driving mode (modes 3 and 4).

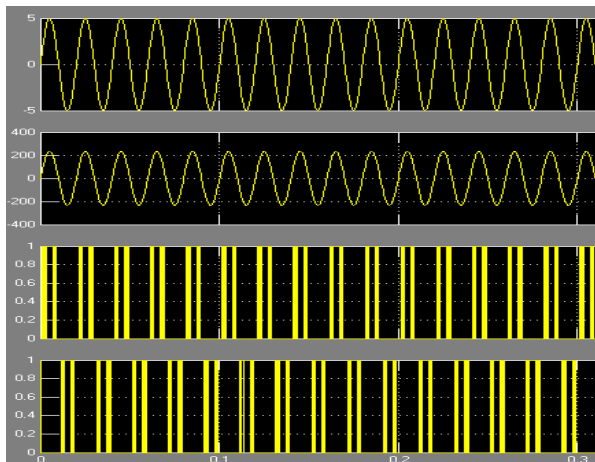

Grid charging (mode 5).

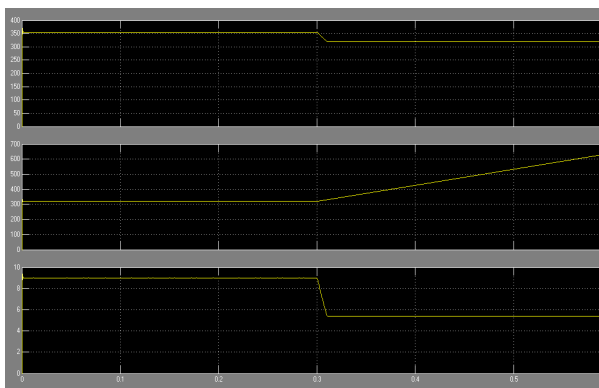

PV charging mode 6 (stages 1–2).

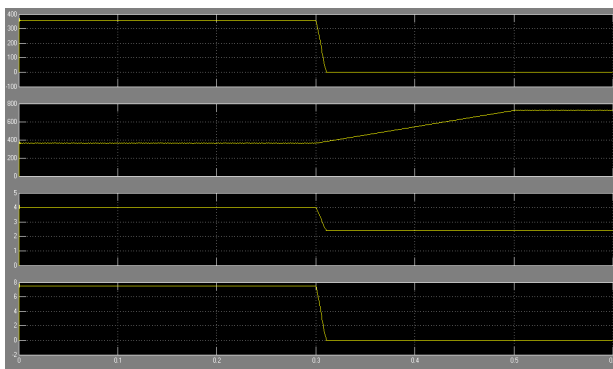

PV charging mode 6 (stages 2–3).

Fuel cell , Photovoltaic solar system, battery and grid connected Hybrid Electric system is developed in the proposed circuit configuration. So the reliability of the supply and the efficiency of the system get improved as a result. Total circuit is simulated in the power graphical user interfacing environment in MATLAB software and results are analyzed in fast fourier transformation analysis. SRM motor drive shows high efficiency and reliability characteristics than compare with the existing system

## REFERENCES

[1] Yihua Hu, Chun Gan, and Wenping Cao, “Solar PV powered SRM drive for Evs with flexible energy control functions,” *IEEE Trans. Ind. Electron.*, vol. 52, no. 4, pp. 1063–1070, July/Aug.2016.

[2] A. Emadi, L. Young-Joo, and K. Rajashekara, “Power electronics and motor drives in electric, hybrid electric, and plug-in hybrid electric vehicles,” *IEEE Trans. Ind. Electron.*, vol. 55, no. 6, pp. 2237–2245, Jun.2008.

[3] A. Kuperman, U. Levy, J. Goren, A. Zafransky, and A. Savernin, “Battery charger for electric vehicle traction battery switch station,” *IEEE Trans. Ind. Electron.*, vol. 60, no. 12, pp. 5391–5399, Dec. 2013.

[4] Y. Hu, C. Gan, W. Cao, W. Li, and S. Finney, “Central-tapped node linked modular fault tolerance topology for SRM based EV/HEV applications,” *IEEE Trans. Power Electron.*, vol. 31, no. 2, pp. 1541–1554, Feb. 2016.

## CONCLUSION





- [5] Y. Hu, X. Song, W. Cao, and B. Ji, "New SR drive with integrated charging capacity for plug-in hybrid electric vehicles (PHEVs)," *IEEE Trans. Ind. Electron.*, vol. 61, no. 10, pp. 5722–5731, Oct. 2014.
- [6] S. G. Li, S. M. Sharkh, F. C. Walsh, and C. N. Zhang, "Energy and battery management of a plug-in series hybrid electric vehicle using fuzzy logic," *IEEE Trans. Veh. Technol.*, vol. 60, no. 8, pp. 3571–3585, Oct. 2011.
- [7] H. Kim, M. Y. Kim, and G. W. Moon, "A modularized charge equalizer using battery monitoring IC for series-connected Li-ion battery strings in electric vehicles," *IEEE Trans. Power Electron.*, vol. 28, no. 8, pp. 3779–3787, May 2013.
- [8] Ping, Z. Jing, L. Ranran, T. Chengde, and W. Qian, "Magnetic characteristics investigation of an axial–axial flux compound- structure PMSM used for HEVs," *IEEE Trans. Magn.*, vol. 46, no. 6, pp. 2191–2194, Jun. 2010.
- [9] A. Kolli, O. Béthoux, A. De Bernardinis, E. Labouré, and G. Coquery, "Space- vector PWM control synthesis for an H-bridge drive in electric vehicles," *IEEE Trans. Veh. Technol.*, vol. 62, no. 6, pp. 2441–2452, Jul. 2013.
- [10] Y. Hu, C. Gan, W. Cao, W. Li, and S. Finney, "Central-tapped node linked modular fault tolerance topology for SRM based EV/HEV applications," *IEEE Trans. Power Electron.*, vol. 31, no. 2, pp. 1541–1554, Feb. 2016.
- [11] S. M. Yang and J. Y. Chen, "Controlled dynamic braking for or switched reluctance motor drives with a rectifier front end," *IEEE Trans. Ind. Electron.*, vol. 60, no. 11, pp. 4913–4919, Nov. 2013.
- [13] B. Bilgin, A. Emadi, and M. Krishnamurthy, "Comprehensive evaluation of the dynamic performance of a 6/10 SRM for traction application in PHEVs," *IEEE Trans. Ind. Electron.*, vol. 60, no. 7, pp. 2564–2575, Jul. 2013.
- [14] M. Takeno, A. Chiba, N. Hoshi, S. Ogasawara, M. Takemoto, and M. Rahman, "Test results and torque improvement of the 50-kW switched reluctance motor designed for hybrid electric vehicles," *IEEE Trans. Ind. Appl.*, vol. 48, no. 4, pp. 1327–1334, Jul./Aug. 2012.
- [15] A. Chiba, M. Takeno, N. Hoshi, M. Takemoto, S. Ogasawara, and M. A. Rahman, "Consideration of number of series turns in switched reluctance traction motor competitive to HEV IPMSM," *IEEE Trans. Ind. Appl.*, vol. 48, no. 6, pp. 2333–2340, Nov./Dec. 2012.
- pp. 5696–5710, Oct. 2014.
- [16] I. Boldea, L. N. Tutelea, L. Parsa, and D. Dorrell, "Automotive electric propulsion systems with reduced or no permanent magnets: An overview," *IEEE Trans. Ind. Electron.*, vol. 60, no. 9,