



Closed Loop Control of PV High Voltage Gain DC-DC converter with Two-Input Boost-stages

1S.Sankara Prasad , 2 G.Lakshmi Narayana , 3T.VijayBharadwaz , 4 M.Nagendra Babu ,
5 P.Rufus Kumar ,

1Assistant Professor,2,3,4,5B-techstudents Scholar

1,2,3,4,5DepartmentofElectrical&ElectronicsEngineering,

1,2,3,4,5G.PullaiahCollegeofEngineeringandTechnology,Nandik

otkurRd,NearVenkayapalle,Pasupula

Village,Kurnool,AndhraPradesh518002

Abstract: Dc-dc converter is a device which produces a dc output voltage when a dc input is given. If output voltage needed is higher than input voltage we go for boost converter. The conventional boost converter can be used for step up applications because of low conduction loss, simple structure and low cost. However, it is not suitable for high step-up applications. Generally conventional boost converters have been used to obtain higher output voltage than the input voltage. When these boost converters are operated for high ratios it leads to high voltage and current stress on the switch. Hence an interleaving technique of boost converter has been presented. This method of approach can be used in high power applications to produce high voltage gain when compared to the conventional boost converter. A simple dc-dc boost converter are unable to provide high step-up voltage gains due to the effect of power switches, rectifier diodes, and the equivalent series resistance of inductor and capacitors. In this paper proposes new dc-dc converter to achieve high voltage gain without an extremely high duty ratio. In the proposed converters, two inductors with the same level of inductance are charged in parallel during the switch –on period and are discharged in series during the switch-off period. In this converter mainly proposed converter. That is used for PV system. To achieve high-voltage conversion ratios, a new family of high-voltage-gain dc–dc power electronic converters has been introduced. The proposed converter can be used to draw power from two independent dc sources as a multiport converter or one source in an interleaved manner. They draw continuous input current from both the input sources with low current ripple which is required in many applications, e.g., solar. Several diode-capacitor stages are cascaded together to boost up the voltage which limits the voltage Stresses on the switches, diodes, and capacitor. In extension the input DC source is replaced with PV system and closed loop control is used to maintain output current is constant.

Key words: conventional boost converter, DC source,switches, diodes, and capacitor

(I) INTRODUCTION

With the increased penetration of renewable energy sources and energy storage, high-voltage-gain dc–dc power electronic converters find increased applications in green energy systems. They can be used to interface low voltage sources like fuel cells, photovoltaic (PV) panels, batteries, etc., to the 400-V bus in a dc micro grid system (see Fig.1) [1]. They also find applications in different types of electronic equipment such as high-intensity-discharge lamps for automobile headlamps, servo-motor drives, X-ray power generators, computer periphery power supplies, and uninterruptible power supplies [4].

To achieve high voltage gains, classical boost and buck-boost converters require large switch duty ratios. Large duty cycles result in high current

stress in the boost switch. The maximum voltage gain that can be achieved is constrained by the parasitic resistive components in the circuit and the efficiency is drastically reduced for large duty ratios. There are diode reverse recovery problems because the diode conducts for a short period of time. Also, larger ripples on the high input current and output voltage would further degrade the efficiency of the converter [5]. Typically high-frequency transformers or coupled inductors are used to achieve high-voltage conversion ratios . The transformer design is complicated and the leakage inductances

increase for achieving larger gains, as it requires higher number of winding turns. This leads to voltage spikes across the switches and voltage clamping techniques are required to limit voltage stresses on the switches. Consequently, it makes the design more complicated. To achieve high-voltage conversion ratios, a new family of high-voltage-gain dc–dc power electronic converters has been introduced.

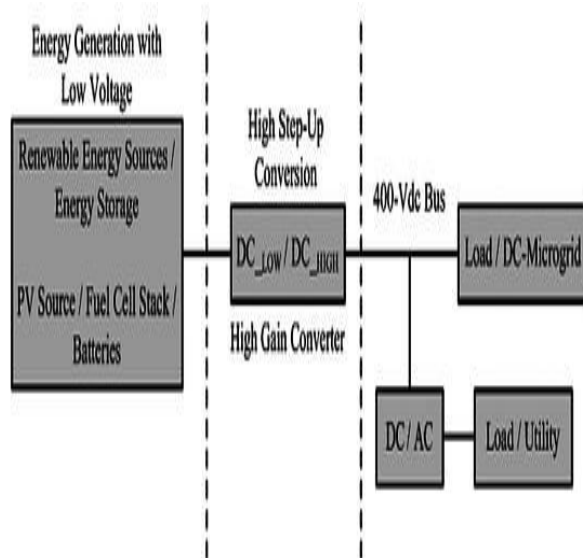

Fig.1. High-voltage-gain dc–dc converter in dc microgrid system

The proposed converter can be used to draw power from two independent dc sources as a multiport converter [16], [17] or one source in an interleaved manner. They draw continuous input current from both the input sources with low current ripple which is required in many applications, e.g., solar. Several diode-capacitor stages are cascaded together to boost up the voltage which limits the voltage stresses on the switches, diodes, and capacitors. Due to the advantages listed above, these converters are good solutions to integrate solar panels into a dc microgrid. In conventional approaches, as the output voltage of PV panel is low, several panels are connected in series when connecting the PV array to the 400-V dc bus through conventional step-up converters. This results in reduced system reliability which can be addressed by connecting high-voltage-gain converter to each individual PV panel. Moreover, since it is a multiport converter with a high voltage gain, independent sources can be connected and power sharing, MPPT algorithms, etc., can be implemented independently at each input port.

Similar converters with interleaved boost input have been proposed earlier using the

Cockcroft–Walton (CW) voltage multiplier (VM) [18], [19]. Current fed converters are superior in comparison to the voltage fed counterparts as they have lower input current ripple [19]. The limitation with the CW-based converters is that the output impedance increases rapidly with the number of multiplying stages [20]. The efficiency and the output voltage regulation of these converters depend on the output impedance; thus, for high gains the converter efficiency would be affected.

II Topology Introduction and Modes Of Operation

The proposed converter is inspired from a Dickson charge pump [20]. Diode-capacitor VM stages are integrated with two boost stages at the input. The VM stages are used to help the boost stage achieve a higher overall voltage gain. The voltage conversion ratio depends on the number of VM stages and the switch duty ratios of the input boost stages. Fig.2 shows the proposed converter with four VM stages. For simplicity and better understanding, the operation of the converter with four multiplier stages has been explained here. Similar analysis can be expanded for a converter with N stages.

For normal operation of the proposed converter, there should be some overlapping time when both the switches are ON and also one of the switches should be ON at any given time (see Fig.3). Therefore, the converter has three modes of operation. The proposed converter can operate when the switch duty ratios are small and there is no overlap time between the conduction of the switches. However, this mode of operation is not of interest as it leads to smaller voltage gains.

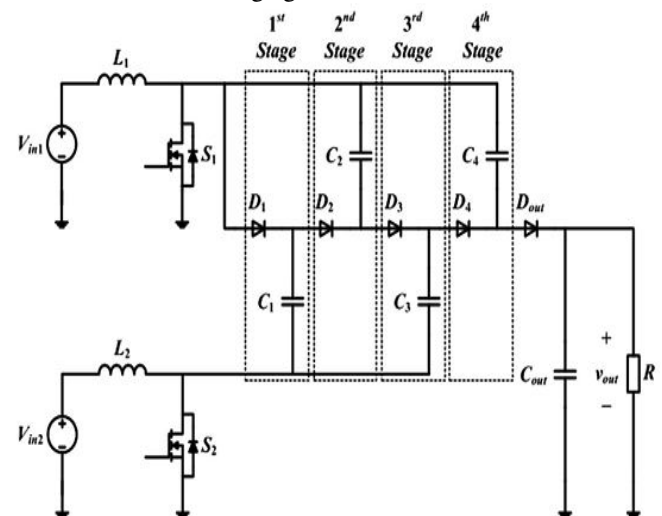

Fig.2. Proposed high-voltage-gain dc–dc converter with four VM stages

1. Mode-I

In this mode, both switches S_1 and S_2 are ON. Both the inductors are charged from their input sources V_{in1} and V_{in2} . The current in both the inductors rise linearly. The diodes in different VM stages are reverse biased and do not conduct. The VM capacitor voltages remain unchanged and the output diode D_{out} is reverse biased (see Fig.4); thus, the load is supplied by the output capacitor C_{out} .

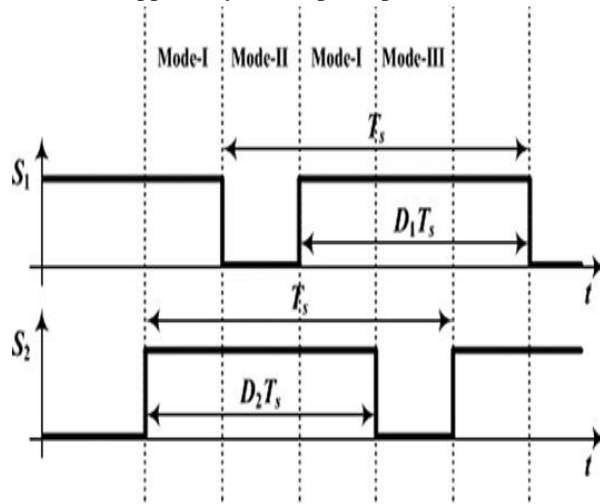

Fig.3. Switching signals for the input boost stage for the proposed converter

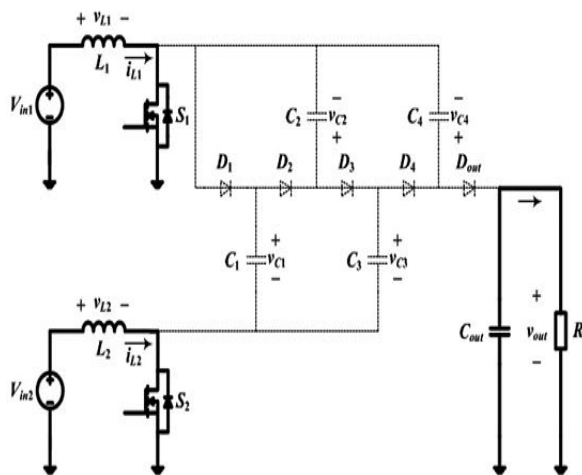

Fig.4. Mode-I of operation for the proposed converter with four VM stages

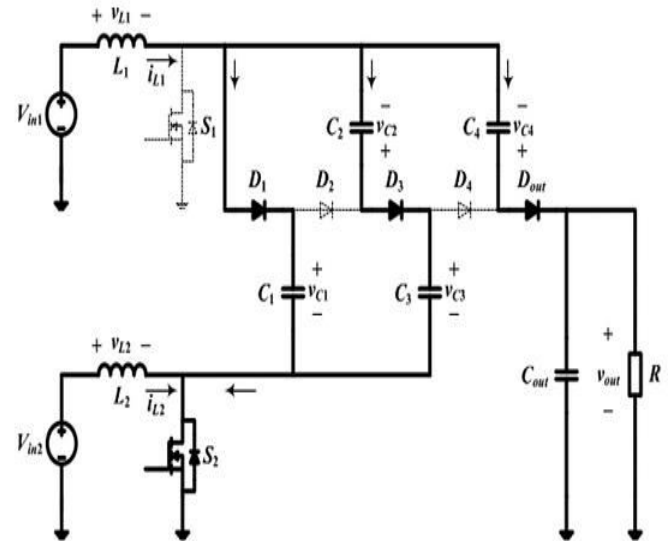

Fig.5. Mode-II of operation for the proposed converter with four VM stages

2. Mode-II

In this mode, switch S_1 is OFF and S_2 is ON (see Fig.5). All the odd numbered diodes are forward biased and the inductor current i_{L1} flows through the VM capacitors charging the odd numbered capacitors (C_1, C_3, \dots) and discharging the even numbered capacitors (C_2, C_4, \dots). If the number of VM stages is odd, then the output diode D_{out} is reverse biased and the load is supplied by the output capacitor. However, if the number of VM stages is even, then the output diode is forward biased charging the output capacitor and supplying the load.

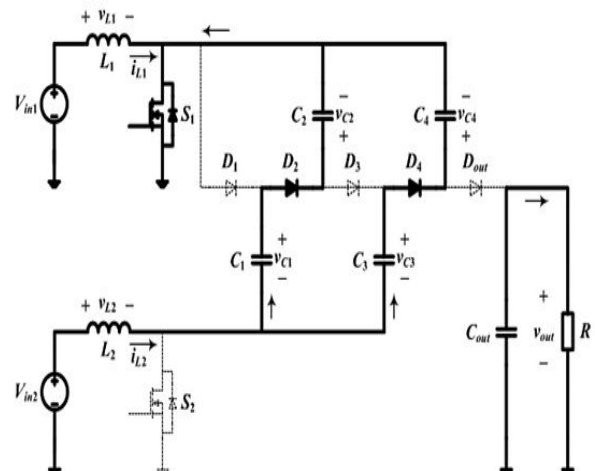

Fig.6. Mode-III of operation for the proposed converter with four VM stages

In the particular case considered here, since there are four VM stages, the output diode is forward biased.

3. Mode-III

In this mode, switch S_1 is ON and S_2 is OFF (see Fig.3.6). Now, the even numbered diodes are forward biased and the inductor current i_{L_2} flows through the VM capacitors charging the even numbered capacitors and discharging the odd numbered capacitors. If the number of VM stages is odd, then the output diode D_{out} is forward biased charging the output capacitor and supplying the load. However, if the number of VM stages is even, then the output diode is reverse biased and the load is supplied by the output capacitor.

III VOLTAGE GAIN OF THE CONVERTER

The charge is transferred progressively from input to the output by charging the VM stage capacitors. For a converter with four stages of VM (see Fig.2), the voltage gain can be derived from the volt-sec balance of the boost inductors. For L_1 , one can write

$$\langle v_{L1} \rangle = 0 \quad (1)$$

Therefore, from Fig.5, it can be observed that the capacitor voltages can be written in terms of upper boost switching node voltage as

$$V_{C1} = V_{C3} - V_{C2} = V_{out} - V_{C4} = \frac{V_{in1}}{(1-d_1)} \quad (2)$$

where d_1 is the switching duty cycle for S_1 . Similarly, from the volt-sec balance of the lower leg boost inductor L_2 , one can write the capacitor voltages (see Fig.3.6) in terms of lower boost switching node voltage as

$$V_{C2} - V_{C1} = V_{C4} - V_{C3} = \frac{V_{in2}}{(1-d_2)} \quad (3)$$

where d_2 is the switching duty cycle for S_2 .

From (2) and (3), the capacitor voltages for the proposed converter with four VM stages can be derived as

$$V_{C1} = \frac{V_{in1}}{(1-d_1)} \quad (4)$$

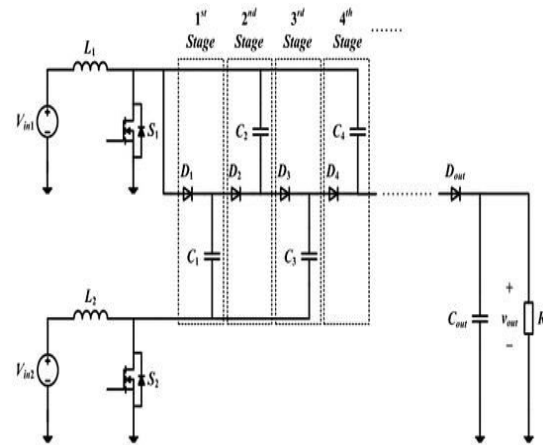

Fig.7. Proposed converter with N number of VM stages

$$\begin{aligned} V_{C2} &= \frac{V_{in1}}{(1-d_1)} + \frac{V_{in2}}{(1-d_2)} \\ V_{C3} &= \frac{2V_{in1}}{(1-d_1)} + \frac{V_{in2}}{(1-d_2)} \\ V_{C4} &= \frac{2V_{in1}}{(1-d_1)} + \frac{2V_{in2}}{(1-d_2)} \end{aligned} \quad (4)$$

The output voltage is derived from (2), which is given by

$$V_{out} = V_{C4} + \frac{V_{in1}}{(1-d_1)} = \frac{3V_{in1}}{(1-d_1)} + \frac{2V_{in2}}{(1-d_2)} \quad (5)$$

Similar analysis can be extended to a converter with N number of VM stages (see Fig.7). Thus, the VM stage capacitor voltages are given by

$$V_{Cn} = \left(\frac{n+1}{2}\right) \frac{V_{in1}}{(1-d_1)} + \left(\frac{n-1}{2}\right) \frac{V_{in2}}{(1-d_2)}$$

if n is odd & $n \leq N$,

$$V_{Cn} = \left(\frac{n}{2}\right) \frac{V_{in1}}{(1-d_1)} + \left(\frac{n}{2}\right) \frac{V_{in2}}{(1-d_2)}$$

if n is even & $n \leq N$.

(6)

The output voltage equation of the converter with N number of VM stages depends on whether N is odd or even and is given by

$$V_{out} = V_{CN} + \frac{V_{in2}}{(1-d_2)} \quad \text{if } N \text{ is odd}$$

$$= \left(\frac{N+1}{2}\right) \frac{V_{in1}}{(1-d_1)} + \left(\frac{N+1}{2}\right) \frac{V_{in2}}{(1-d_2)} \quad (7)$$

$$V_{out} = V_{CN} + \frac{V_{in1}}{(1-d_1)} \text{ if } N \text{ is even}$$

$$= \left(\frac{N+2}{2}\right) \frac{V_{in1}}{(1-d_1)} + \left(\frac{N}{2}\right) \frac{V_{in2}}{(1-d_2)} \quad (8)$$

When the converter operates in an interleaved manner with single input source, if d_1 and d_2 are also chosen to be identical, i.e., $d_1 = d_2 = d$, then the output voltage is given by

$$V_{out} = (N+1) \frac{V_{in}}{(1-d)} \quad (9)$$

In [21], an interleaved boost power factor corrected converter with voltage-doublers characteristics is introduced. It can be observed that it is a special case of the proposed converter with a single VM stage ($N = 1$).

It is worth noting that there is an alternative to the proposed converter (see Fig.8) where diode D_1 of the first VM stage is connected to the lower boost switching node and capacitor C_1 is connected to the upper boost switching node (compare with Fig.7).

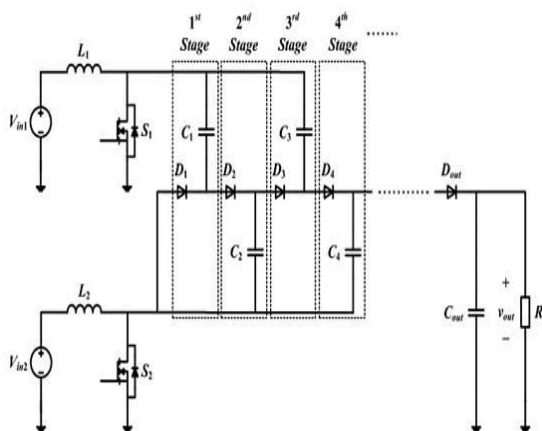

Fig.8. Alternative to the proposed converter with N number of VM stages

The output voltage equation for this alternative topology is given by

$$V_{out} = \left(\frac{N+1}{2}\right) \frac{V_{in1}}{(1-d_1)} + \left(\frac{N+1}{2}\right) \frac{V_{in2}}{(1-d_2)} \text{ if } N \text{ is odd} \quad (10)$$

$$V_{out} = \left(\frac{N}{2}\right) \frac{V_{in1}}{(1-d_1)} + \left(\frac{N+2}{2}\right) \frac{V_{in2}}{(1-d_2)} \text{ if } N \text{ is even.} \quad (11)$$

For $N = 1$, if one combines the topology depicted in Fig.7 with its alternative (see Fig. 8), then the resulting converter in Fig.9 is similar to the multiphase converter introduced in [22].

In general, when both topologies with N number of VM stages are combined, then the resulting converter is shown in Fig.10. When N is odd, then from (7) and (10), the voltage gain of the combined topology is given by

$$V_{out} = \left(\frac{N+1}{2}\right) \frac{V_{in1}}{(1-d_1)} + \left(\frac{N+1}{2}\right) \frac{V_{in2}}{(1-d_2)} \text{ if } N \text{ is odd.} \quad (12)$$

In this case, the original topology and its alternative each process half of the output power. In other words, the average currents of D_{out1} and D_{out2} are equal.

When N is even, the output voltage of the combined topology would be either (8) or (11) and will be dictated by the topology that provides a higher output voltage. Both legs (see Fig.10) would compete with each other and only one of the output diodes (D_{out1} and D_{out2}) would process the entire power while the other will be reverse biased. When N is even, putting the converters in parallel only makes sense if there is only one source used and $d_1 = d_2$. In that case both (8) and (11) determine the output voltage to be

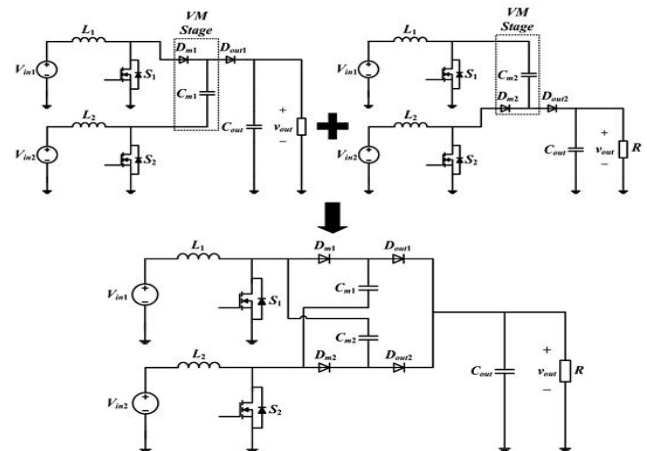

Fig.9. Combined topology with single VM stage

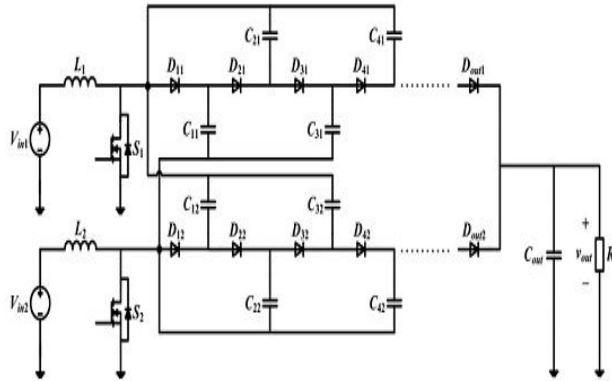

Fig.10. Combined topology with N number of VM stages

$$V_{out} = (N + 1) \frac{V_{in}}{(1 - d)} \quad \text{if } N \text{ is even} \quad (13)$$

For the combined topology with a single input source and identical duty ratios d_1 and d_2 , i.e., $d_1 = d_2 = d$, both the boost stages will always have symmetrical inductor and switch currents irrespective of the number of VM stages.

Closed loop Operation

The closed loop operation carried out by the voltage controller (PI controller) processes the error signal and produces appropriate current signal (i_s). The current signal (i_s) is multiplied with unit sinusoidal template which is produced by using phase locked loop (PLL), to produce $i_s \sin \omega t$. The load current i_L subtracted from the $i_s \sin \omega t$ to produce the reference current signal i_s^* . As the boost inductor current can't be alternating, the absolute circuit gives the absolute value of the reference current signal i_s^* that is i_c^* . The actual signal (i_c) and the required reference signal (i_c^*) are given to the current controller to produce the proper gating signal. The current controller adopted is a hysteresis current controller. Upper and lower hysteresis band is created by adding and subtracting a band 'h' with the reference signal i_c^* respectively shown in the Fig. 8. The inductor current is forced to fall within the hysteresis band. When the current goes above the upper hysteresis band, i.e. $i_c^* + h$, the pulse is removed resulting the current forced to fall as the current will flow through the load. When the current goes below the lower hysteresis band i.e. $i_c^* - h$, the pulse is given to the switch, so the current increases linearly.

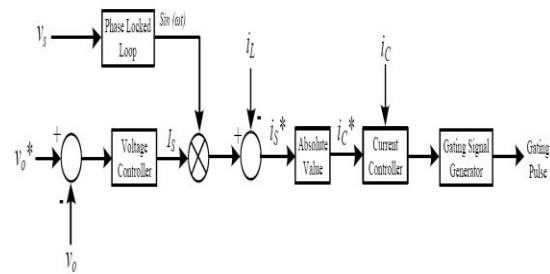

Fig 11 Adopted control scheme for the Closed Loop operation

IV MATLAB/SIMULINK RESULTS

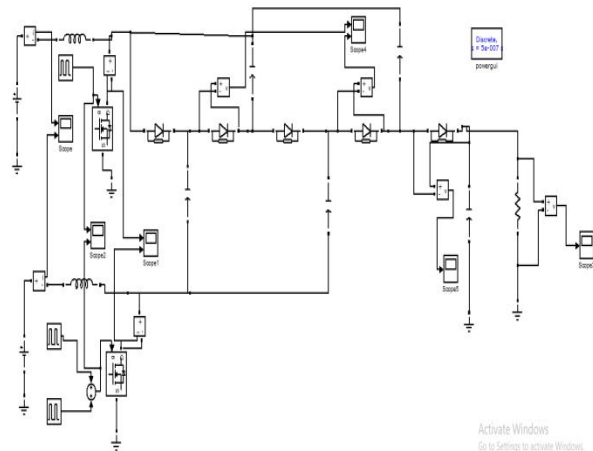

Fig 1: Simulation modeling of high-voltage-gain dc-dc converter

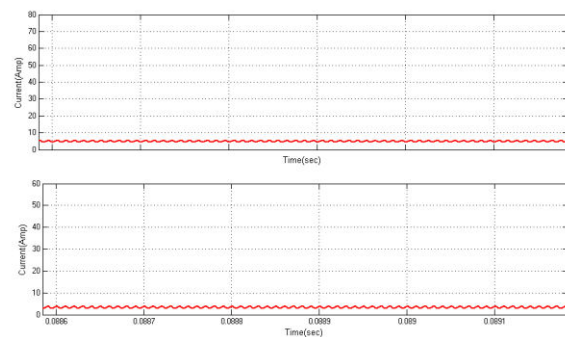

Fig 2: Simulation Waveforms of Inductor Currents at odd stage

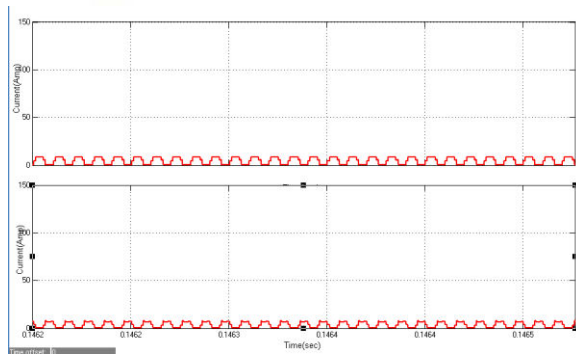

Fig 3: Simulation Waveforms of Inductor Currents at even stage

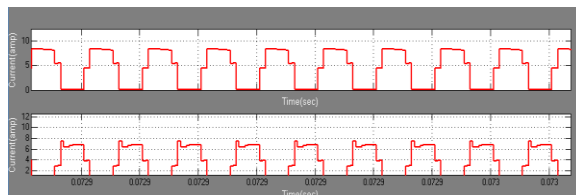

Fig 4: Simulation Waveforms of Switch Currents

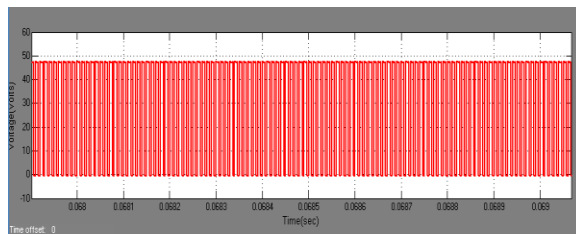

Fig 5: Simulation Waveforms of Diode output Voltage

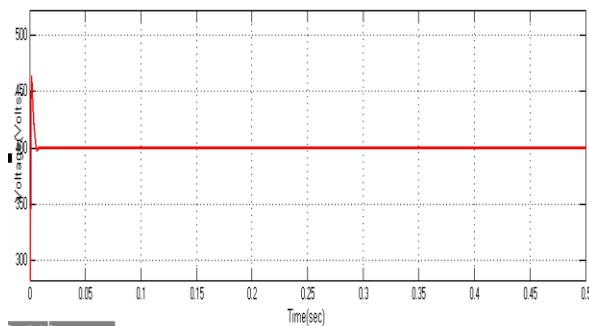

Fig 6: Simulation Waveform of output voltage

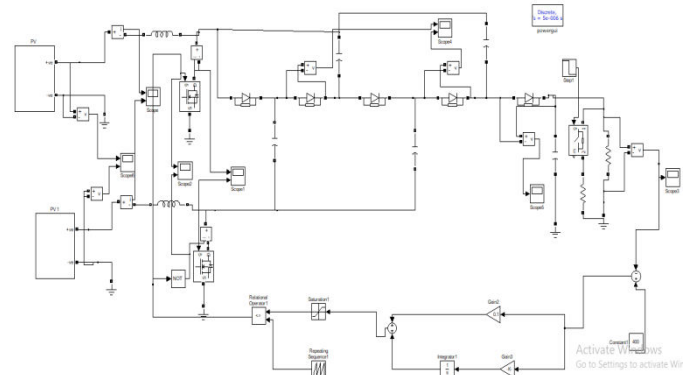

Fig 7: Simulation modeling of PV with Closed loop Circuit

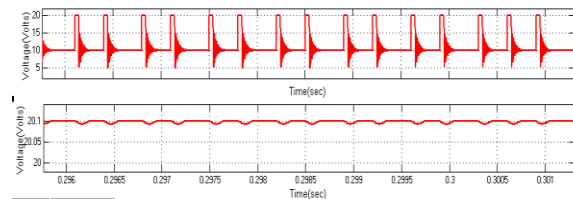

Fig 8: Simulation Voltage waveforms of both PV's

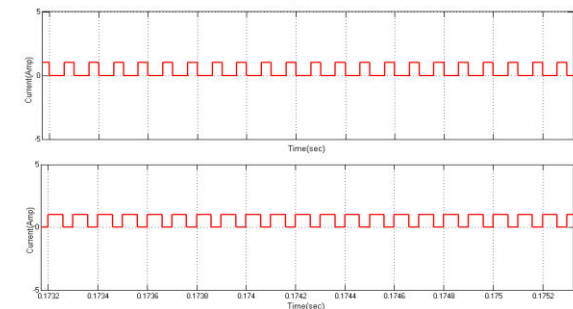

Fig 9: Simulation Waveforms of Switch Currents of Closed loop System

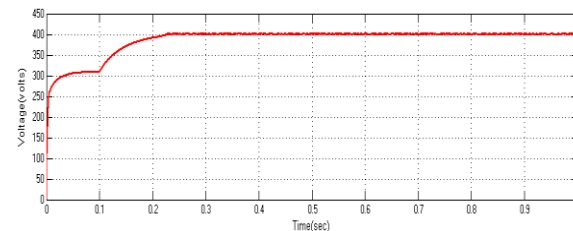

Fig 10: Final output voltage waveform of Closed loop system

CONCLUSION

In this project, a family of novel high-voltage-gain dc-dc converters with two boost stages at the input has been proposed. The proposed



converter is based on diode–capacitor VM stages and the voltage gain is increased by increasing the number of VM stages. It can draw power from two input sources like a multiport converter or operate in an interleaved manner when connected to a single source. One of the advantages of the proposed converter is that since it is a multiport converter with high voltage gain, it has the flexibility to be connected to independent sources while allowing power sharing, MPPT algorithms etc., to be implemented independently at each input port. Furthermore, an alternative topology of the proposed converter has been presented and combining them both would result in a new converter topology. The proposed converter can be used for solar applications where each panel can be individually linked to the 400-V dc bus.

REFERENCES

- [1] S. Jain and V. Agarwal, “A single-stage grid connected inverter topology for solar PV systems with maximum power point tracking,” *IEEE Trans. Power Electron.*, vol. 22, no. 5, pp. 1928–1940, Sep. 2007.
- [2] X. Kong and A. M. Khambadkone, “Analysis and implementation of a high efficiency, interleaved current-fed full bridge converter for fuel cell system,” *IEEE Trans. Power Electron.*, vol. 22, no. 2, pp. 543–550, Mar. 2007.
- [3] C. Liu and J. S. Lai, “Low frequency current ripple reduction technique with active control in a fuel cell power system with inverter load,” *IEEE Trans. Power Electron.*, vol. 22, no. 4, pp. 1429–1436, Jul. 2007.
- [4] E. H. Ismail, M. A. Al-Saffar, A. J. Sabzali, and A. A. Fardoun, “A family of single-switch PWM converters with high step-up conversion ratio,” *IEEE Trans. Circuits Syst. I, Reg. Papers*, vol. 55, no. 4, pp. 1159–1171, May 2008.
- [5] R. W. Erickson and D. Maksimovic, *Fundamentals of Power Electronics*, 2nd ed. Norwell, MA, USA: Kluwer, 2001.
- [6] W. Li and X. He, “A family of interleaved DC–DC converters deduced from a basic cell with winding-cross-coupled inductors (WCCIs) for high step-up or step-down conversions,” *IEEE Trans. Power Electron.*, vol. 23, no. 4, pp. 1791–1801, Jul. 2008.
- [7] W. Li and X. He, “An interleaved winding-coupled boost converter with passive lossless clamp circuits,” *IEEE Trans. Power Electron.*, vol. 22, no. 4, pp. 1499–1507, Jul. 2007.
- [8] W. Li, Y. Zhao, Y. Deng, and X. He, “Interleaved converter with voltage multiplier cell for high step-up and high-efficiency conversion,” *IEEE Trans. Power Electron.*, vol. 25, no. 9, pp. 2397–2408, Sep. 2010.
- [9] Y.-P. Hsieh, J.-F. Chen, T.-J. Liang, and L.-S. Yang, “A novel high step-up DC–DC converter for a microgrid system,” *IEEE Trans. Power Electron.*, vol. 26, no. 4, pp. 1127–1136, Apr. 2011.
- [10] R. Xie, W. Li, Y. Zhao, J. Zhao, X. He, and F. Cao, “Performance analysis of isolated ZVT interleaved converter with winding-cross-coupled inductors and switched-capacitors,” in *Proc. IEEE Energy Convers. Congr. Expo.*, Atlanta, GA, USA, 2010, pp. 2025–2029.
- [11] W. Li, W. Li, X. He, D. Xu, and B. Wu, “General derivation law of nonisolated high-step-up interleaved converters with built-in transformer,” *IEEE Trans. Ind. Electron.*, vol. 59, no. 3, pp. 1650–1661, Mar. 2012.
- [12] K.-C. Tseng, C.-C. Huang, and W.-Y. Shih, “A high step-up converter with a voltage multiplier module for a photovoltaic system,” *IEEE Trans. Power Electron.*, vol. 28, no. 6, pp. 3047–3057, Jun. 2013.
- [13] W. Li, Y. Zhao, J. Wu, and X. He, “Interleaved high step-up converter with winding-cross-coupled inductors and voltage multiplier cells,” *IEEE Trans. Power Electron.*, vol. 27, no. 1, pp. 133–143, Jan. 2012.
- [14] K.-C. Tseng and C.-C. Huang, “High step-up high-efficiency interleaved converter with voltage multiplier module for renewable energy system,” *IEEE Trans. Ind. Electron.*, vol. 61, no. 3, pp. 1311–1319, Mar. 2014.
- [15] K.-C. Tseng and C.-C. Huang, “A high step-up passive absorption circuit used in non-isolated high step-up converter,” in *Proc. IEEE Appl. Power Electron. Conf. Expo.*, Long Beach, CA, USA, 2013, pp. 1966–1971.
- [16] K. Gummi and M. Ferdowsi, “Synthesis of double-input DC–DC converters using single pole triple throw switch as a building block,” in *Proc. IEEE Power Electron. Spec. Conf.*, Rhodes, Greece, 2008, pp. 2819–2823.