

**IOT SMART SPEED BREAKER BASED ON VEHICLE SPEED****Mr. P S K Ganesh Kumar <sup>1</sup>, Mr. P Sudheer Kumar <sup>2</sup>**

<sup>1,2</sup>Assistant Professor, Dept. Of ECE, A.M.Reddy Memorial College of Engineering and Technology, Narasaraopet

**ABSTRACT**

The proliferation of urbanization and rapid growth in vehicular traffic have necessitated innovative solutions for ensuring road safety. Conventional speed breakers, while effective, can be hazardous if not designed or placed optimally. This paper proposes an IoT-enabled smart speed breaker system that dynamically adjusts its height based on the approaching vehicle's speed. Leveraging a combination of sensors, including radar, lidar, and cameras, the system accurately detects vehicle speed and adjusts the speed breaker's height accordingly. For instance, if a vehicle is approaching at a high speed, the speed breaker elevates to its maximum height to slow it down effectively. Conversely, if a vehicle is approaching at a low speed, the speed breaker lowers its height to minimize discomfort to passengers and reduce wear on the vehicle. The system also integrates with existing traffic management infrastructure, enabling real-time monitoring and optimization of traffic flow. Furthermore, the proposed system incorporates energy harvesting technologies to ensure sustainability and minimize environmental impact. The IoT-enabled smart speed breaker system offers a novel solution for enhancing road safety, reducing traffic congestion, and promoting a more sustainable transportation ecosystem.

**INTRODUCTION**

Traditional speed breakers pose a fixed obstacle, inconveniencing compliant drivers while impacting fuel efficiency, vehicle wear, and emergency vehicle passage. They contribute to congestion and offer a crude, one-size-fits-all approach to speed enforcement, highlighting the need for more intelligent solutions that differentiate between responsible and reckless drivers. This necessitates a shift towards adaptive traffic management strategies leveraging technology.

This project introduces an IoT-enabled smart speed breaker system designed to overcome these limitations. The system uses sensors to detect approaching vehicle speeds, transmitting data to a central processing unit. Algorithms then determine if a vehicle is speeding, triggering actuators to raise the speed breaker only when necessary. This dynamic adjustment allows compliant vehicles to pass unimpeded, while effectively deterring speeding. The IoT connectivity enables remote monitoring, data collection, and potential integration with other smart city systems.

The smart speed breaker system offers numerous advantages, including improved traffic flow, enhanced road safety, increased passenger comfort, and reduced vehicle wear. Its data collection capabilities provide valuable insights for traffic management optimization and urban planning. Integration with other smart city initiatives is possible, and future enhancements could include automated alerts, GPS integration, and AI-powered traffic

prediction. This technology represents a significant step towards intelligent, efficient, and sustainable traffic management.

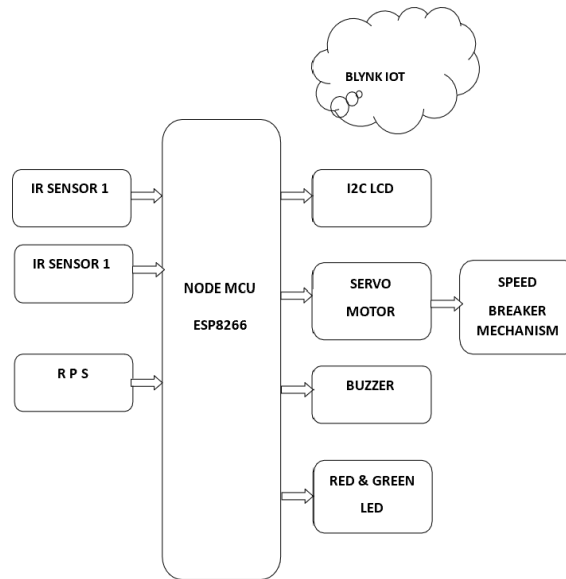

Figure.1 Block Diagram

## LITERATURE SURVEY

### **Title: Intelligent traffic light & speed breaker flatten system.**

Author: P.Janardhana Reddy.et.al. Int. Journal of Engineering Research and Application  
ISSN: 2248-9622, Vol. 7, Issue 11, (Part -2) November 2017, pp.68-71

Methodology : The main aim of the speed breakers was reducing the vehicle speed, if the passenger had reduced his vehicle speed there is no need of the speed breaker. So, we will use the sensors to monitor the vehicle speed while passenger was arrived to the speed breaker.

### **Title: TRAFFIC LIGHT CONTROLLER USING EMBEDDED SYSTEM”**

Author: Prof. Mrs. Vidya Patil Second International Conference on Emerging Trends in Engineering and Technology, ICETET-2012.

Methodology: This paper is about intelligent traffic control and management system which uses intelligent components like RFID, IR sensor, microcontroller. It helps peoples about the information about the traffic density in specific area. The paper proposes a smart speed breaker system using image processing to control the speed of vehicles. The system consists of a camera and an image processing unit that detect the speed of the approaching vehicle and adjust the height of the speed breaker accordingly. The system effectively reduces the chances of accidents caused by speeding vehicles and outperforms the conventional speed breaker system. The authors have provided a detailed explanation of the system's design and implementation, which can be useful for researchers and practitioners interested in developing similar systems.

The paper proposes an automatic intelligent speed breaker system that uses image processing techniques to detect the speed of approaching vehicles and adjust the height of the speed breaker accordingly. The proposed system aims to reduce the chances of accidents caused by speeding vehicles. The authors present the design and implementation of the system, which includes the selection of hardware components, image processing algorithms, and control logic. The experiments conducted to evaluate the performance of the proposed system show that it effectively controls the speed of vehicles and has the potential to improve road safety.

## PROPOSED SYSTEM

The paper proposes an intelligent speed breaker system for road safety that uses image processing. The system comprises a camera and an image processing unit that detect the speed of approaching vehicles and adjust the height of the speed breaker accordingly. The authors have presented the design and implementation of the proposed system and conducted experiments to evaluate its performance. The results show that the proposed system effectively controls the speed of vehicles and can improve road safety. The paper can be useful for researchers and practitioners interested in developing similar systems.

### Proposed system

of "IOT SMART SPEED BREAKER BASED ON VEHICLE SPEED". The block diagram depicts an IoT-based smart speed breaker system. At its core is a NodeMCU ESP8266 microcontroller, which acts as the central processing unit. The system senses approaching vehicles using two IR sensors and potentially another sensor labeled "RPS" (likely a speed sensor). These sensors provide input to the NodeMCU, which calculates the vehicle's speed. Based on this speed, the NodeMCU makes a decision: if the vehicle is speeding, it activates a servo motor, which in turn engages the speed breaker mechanism. Simultaneously, a red LED illuminates, a buzzer sounds, and a message is displayed on a 120 LCD, alerting both the driver and nearby traffic.

This information, including the activation of the speed breaker, is also transmitted to a Blynk IoT server, enabling remote monitoring and data logging. If the vehicle is not speeding, the speed breaker remains inactive, and a green LED might be illuminated. The system's components, including the sensors, servo motor, indicators, and NodeMCU, are all powered by a power source (not explicitly shown in the diagram). The NodeMCU processes the sensor data, controls the servo motor and indicators, and manages the communication with the Blynk IoT server.

The IoT-based smart speed breaker system designed to dynamically control vehicle speeds and enhance road safety. The system's core component is a NodeMCU ESP8266 microcontroller, which integrates processing capabilities with built-in Wi-Fi connectivity. Two IR sensors, strategically placed along the roadside, detect the passage of vehicles and provide input to the ESP8266. The system likely calculates vehicle speed based on the time it takes to traverse the distance between these sensors, although an additional input labeled "RPS" (possibly referring to rotations per second or a similar speed-related metric) is also present, suggesting a potentially more direct method of speed measurement. If the calculated speed exceeds a predefined threshold, the ESP8266 triggers a series of actions.

Upon detecting a speeding vehicle, the ESP8266 activates a servo motor, which in turn engages the physical speed breaker mechanism, creating a bump or obstacle in the road to slow the vehicle down. Simultaneously, a red traffic light is illuminated, signaling the driver to stop. An audible buzzer also sounds to provide an additional alert. The system can display relevant information, such as the vehicle's speed or a warning message, on the LCD screen. Critically, the ESP8266, leveraging its Wi-Fi capabilities, transmits data about the speeding event, including the time, speed, and speed breaker status, to a "BLYNK IOT" server. This connection enables remote monitoring of the system's activity and allows for data logging and analysis. The diagram also indicates the presence of a green LED, which likely serves as a visual indicator during normal operation when no speeding vehicles are detected. The entire system is powered by an unspecified power source, providing the necessary energy for the sensors, microcontroller, actuators, and indicators to function.

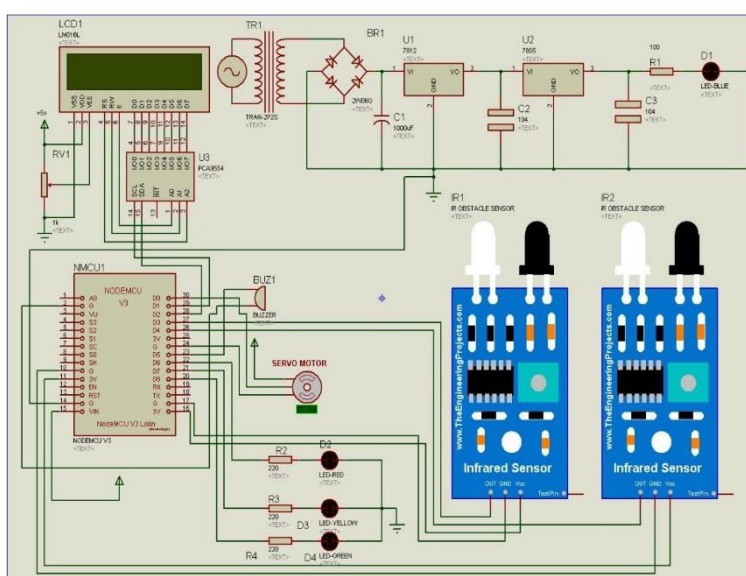

Figure.2 Schematic Diagram

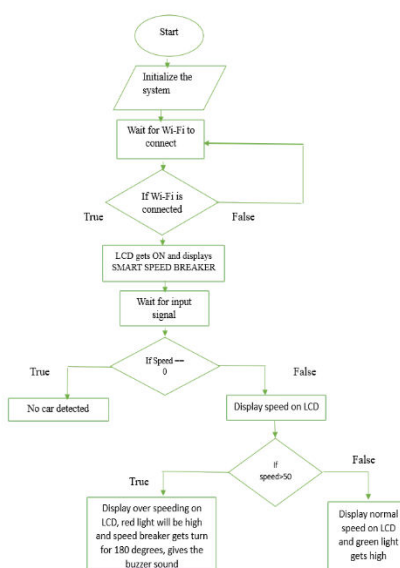

Figure.3 Flow Chart



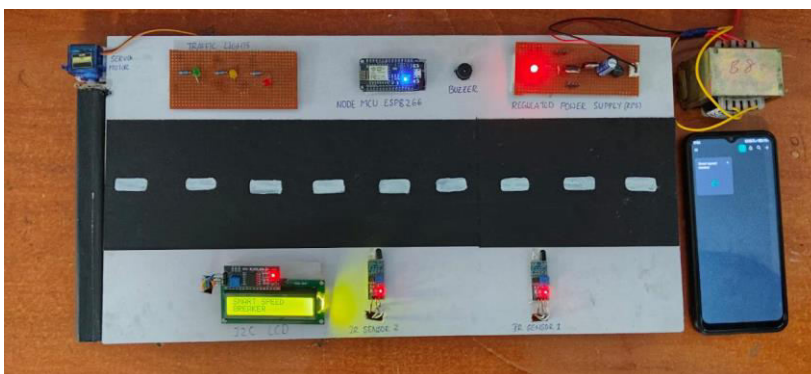

Figure.4 Working Kit

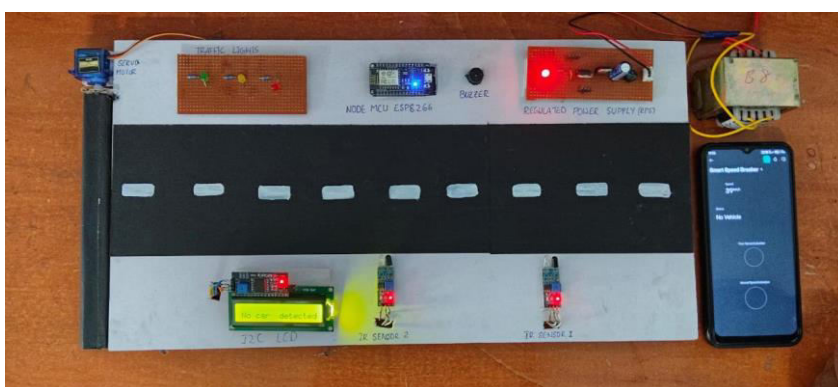

Figure.5 No Vehicle detected

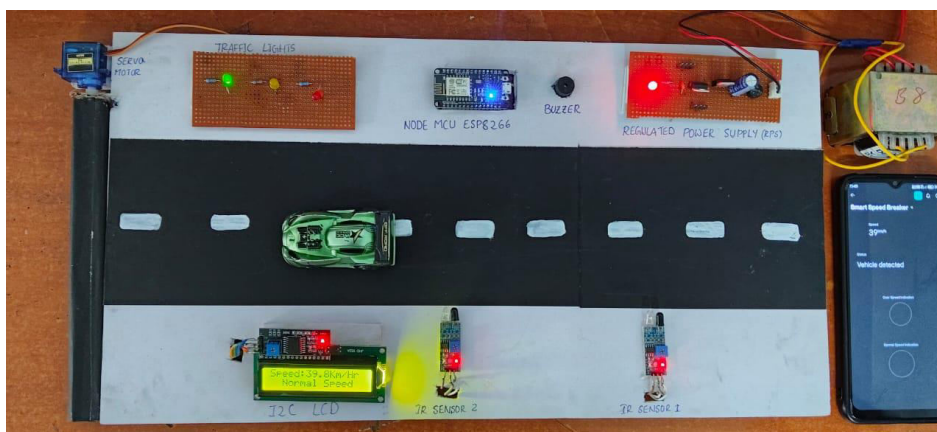

Figure.6 Normal Speed & Status Updated On server

This image showcases a prototype of an IoT-based smart speed breaker system. A toy car triggers IR sensors, simulating a vehicle's approach, which then prompts a NodeMCU ESP8266 to activate a servo motor, raising a small platform to mimic a speed bump. The system includes a traffic light display, an LCD screen showing "Normal Speed", and a buzzer for alerts. A smartphone displaying a Blynk app interface suggests remote monitoring and control capabilities. A regulated power supply and transformer power the setup, while red laser beams (likely added for the photo) highlight the IR sensor paths, demonstrating real-time vehicle detection and a simulated speed control response

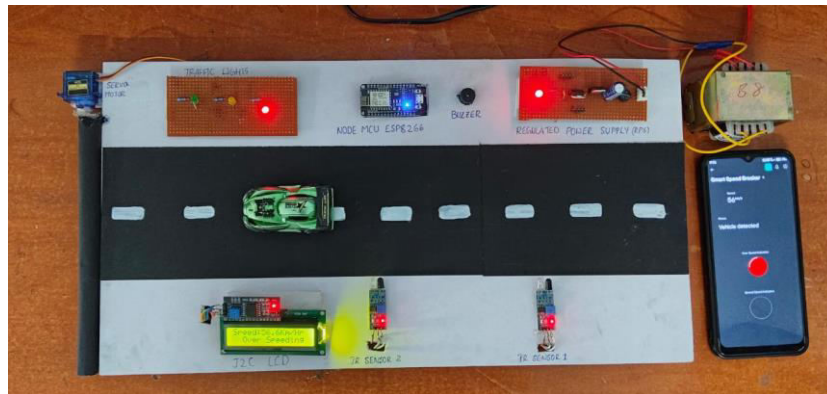

Figure.7 Over Speed

This image shows an IoT-based smart speed breaker prototype. A toy car triggers IR sensors, activating a servo motor (simulating the speed breaker). A NodeMCU ESP8266 processes data, displayed on an LCD as "Over Speed". Traffic lights and a buzzer provide alerts, and a Blynk app enables remote control. A regulated power supply powers the system, demonstrating real-time vehicle detection.

### ADVANTAGES

- **Smart Speed Regulation** – Automatically adjusts height based on vehicle speed, ensuring smooth travel for compliant drivers.
- **Enhanced Road Safety** – Reduces accidents by slowing down overspeeding vehicles in critical areas.
- **Real-Time Monitoring** – IoT integration allows authorities to monitor vehicle speeds and breaker activity remotely.
- **Traffic Flow Optimization** – Prevents unnecessary slowdowns by remaining flat for vehicles moving at legal speeds.
- **Reduced Vehicle Damage** – Minimizes wear and tear on vehicles by eliminating abrupt and fixed speed bumps.

### APPLICATIONS

- **Urban Traffic Management** – Controls vehicle speeds in crowded city areas, improving safety for pedestrians.
- **Highways & Expressways** – Prevents over speeding at accident-prone zones and toll booths.
- **School & Hospital Zones** – Ensures vehicles slow down near sensitive areas, enhancing safety for children and patients.
- **Residential Areas** – Protects pedestrians by enforcing speed limits in neighborhoods.
- **Smart City Infrastructure** – Integrates with IoT-based city monitoring systems for efficient traffic regulation.
- **Toll Booth Areas** – Helps regulate speed before toll collection points to prevent sudden braking.



## CONCLUSION

The IoT-based smart speed breaker system, as presents a compelling solution to the drawbacks of traditional Speed breakers. By utilizing IR sensors to detect approaching vehicles and a NodeMCU ESP8266 to process this data, the system dynamically adjusts the speed breaker's height via a servo motor. This intelligent approach allows compliant vehicles to pass unimpeded, promoting smoother traffic flow and reducing unnecessary wear and tear on vehicles. Simultaneously, it effectively deters speeding by raising the speed breaker when a vehicle exceeds the pre-defined limit, thus enhancing road safety. The inclusion of an LCD displaying "Vehicle detected" and a buzzer provides immediate feedback, while the potential for remote monitoring and control through IoT connectivity offers further advantages for traffic management.

This system represents a significant advancement in traffic calming technology. It addresses the core issue of traditional speed breakers impacting all vehicles regardless of speed. The selective activation of the speed breaker mechanism not only improves efficiency and reduces fuel consumption but also minimizes passenger discomfort and potential cargo damage. Furthermore, the data collected by the system can provide valuable insights into traffic patterns and driver behavior, enabling data-driven decisions for urban planning and traffic management. While the image showcases a simplified setup, it effectively demonstrates the core functionality and potential of this innovative approach to creating safer and more efficient roads.

## FUTURE SCOPE

The future of IoT-based smart speed breakers holds exciting possibilities for enhancing road safety and traffic management. Here are some potential areas for development:

**Multi-sensor fusion:** Combining data from various sensors (radar, lidar, cameras, ultrasonic) for more accurate and robust speed detection, regardless of weather or lighting conditions.

**Vehicle recognition:** Implementing image processing or other technologies to identify vehicle types (cars, trucks, motorcycles) and adjust speed breaker response accordingly.

**Environmental sensors:** Integrating sensors to monitor road conditions (rain, ice) and adapt speed limits and speed breaker behavior for increased safety.



**REFERENCES**

1. S. S. Gawande and S. M. Kazi, "Intelligent speed breaker system using image processing," 2017 International Conference on Nascent Technologies in Engineering (ICNTE), Coimbatore, India, 2017, pp. 1-5. doi: 10.1109/ICNTE.2017.8294583
2. R. S. Suresh Kumar and R. C. Thangavelu, "Automatic image processing based intelligent speed breaker for reducing accidents," 2014 International Conference on Control, Instrumentation, Communication and Computational Technologies (ICCICCT), Kanyakumari, India, 2014, pp. 233-238. doi: 10.1109/ICCICCT.2014.6993038
3. H. K. Singh, A. K. Kori, and K. K. Choudhary, "Intelligent speed breaker for road safety using image processing," 2016 IEEE Uttar Pradesh Section International Conference on Electrical, Computer and Electronics Engineering (UPCON), Varanasi, India, 2016, pp. 307-312. doi: 10.1109/UPCON.2016.7953519
4. S. S. Patel, P. B. Patel, and N. K. Patel, "Real-time automatic number plate recognition system for vehicle tracking using image processing," 2017 International Conference on Inventive Computing and Informatics (ICICI), Coimbatore, India, 2017, pp. 414-419. doi: 10.1109/ICICI.2017.8363287
5. D. B. Joshi, R. V. Dubey, and V. K. Patle, "An overview on sound based classification of vehicles," 2017 International Conference on Intelligent Computing and Control Systems (ICICCS), Madurai, India, 2017, pp. 1066-1070. doi: 10.1109/ICCONS.2017.8250754
6. B. T. Upadhyay, R. K. Singh, and N. Kumar, "An intelligent speed control system using image processing," 2016 IEEE 1st International Conference on Power Electronics, Intelligent Control and Energy Systems (ICPEICES), Delhi, India, 2016, pp. 1-5. doi: 10.1109/ICPEICES.2016.7853313
7. S. S. Gawande and S. M. Kazi, "Smart speed breaker system for speed control of vehicle," 2016 IEEE 7th Power India International Conference (PIICON), Bikaner, India, 2016, pp. 1-5. doi: 10.1109/POWERI.2016.8077338
8. V. Singh, R. Singh, and P. Singh, "Smart speed breaker with intelligent control and warning system," 2016 IEEE 1st International Conference on Power Electronics, Intelligent Control and Energy Systems (ICPEICES), Delhi, India, 2016, pp. 1-6. doi: 10.1109/ICPEICES.2016.7853301