

VEHICLE OVER SPEED INDICATION BASED IOT

¹DR.N SREEKANTH, ²I.SPANDANA, ³J.SHRAVYA, ⁴K.SRAVANI

¹Assistant Professor, Department of Electronics and Communication Engineering, **MALLA REDDY ENGINEERING COLLEGE FOR WOMEN**, Maisammaguda, Dhulapally Kompally, Medchal Rd, M, Secunderabad, Telangana.

^{2,3,4}Student, Department of Electronics and Communication Engineering, **MALLA REDDY ENGINEERING COLLEGE FOR WOMEN**, Maisammaguda, Dhulapally Kompally, Medchal Rd, M, Secunderabad, Telangana.

ABSTRACT

Automatic vehicle monitoring has become increasingly vital in recent years due to rising road accident rates. This project aims to develop a system that identifies vehicles exceeding specified speed limits and promptly alerts relevant authorities. With the growing need for effective speed detection, our Smart Vehicle Overspeeding Detector utilizes IoT technology to intelligently gather and analyze traffic data. The system integrates components such as GPS modules, radar systems, and Google Maps to monitor vehicle speeds, with capabilities for recording and sharing this information. Safe zones are automatically identified through GPS and IoT technologies, while the electronic tracking device operates on a 12V lithium battery, providing 5 to 10 hours of monitoring. The smart over speeding sensor works in tandem with IoT to regulate vehicle speeds in high-risk areas, contributing to accident prevention. Data is transmitted wirelessly, and when over speeding is detected, an alarm is triggered to alert the driver. This innovative approach aims to significantly reduce accident-related fatalities, particularly in Middle Eastern countries like Oman.

Keywords : IoT, Smart vehicle over speeding sensor, accident prevention system in Oman, vehicle-to-vehicle interaction.

INTRODUCTION

Automatic vehicle monitoring has emerged as a critical necessity in recent years, especially as road accident rates continue to rise. To address this pressing issue, our project proposes an innovative system that detects speeding vehicles exceeding designated speed limits and promptly alerts the relevant authorities. The need for effective speed monitoring solutions is more urgent than ever, particularly in regions like the Middle East and Oman, where high accident rates have been reported. This

project leverages the capabilities of modern technologies, including the Internet of Things (IoT), GPS modules, radar systems, and Google Maps, to create a smart vehicle overspeeding detector. By utilizing these technologies, our system can automatically collect and analyze road traffic information, enhancing the overall intelligence of traffic management. The core of the system includes a smart vehicle overspeeding sensor that operates in conjunction with IoT frameworks. This sensor is designed to

monitor and record vehicle speed, storing critical data for further analysis and sharing it wirelessly. By identifying safe zones using GPS and IoT technology, the system can significantly reduce the likelihood of accidents, particularly in high-risk areas. Powered by a 12V lithium battery with a lifespan of 5 to 10 hours, the electronic tracking device ensures continuous monitoring. When an overspeeding vehicle is detected, the sensor activates an alarm, providing immediate feedback to the driver and alerting nearby authorities. By implementing this intelligent overspeeding detection system, we aim to contribute to the reduction of traffic-related fatalities and improve road safety in Oman and beyond. Our goal is to harness technology not only to enhance driver awareness but also to foster safer driving environments through proactive measures and vehicle-to-vehicle interactions.

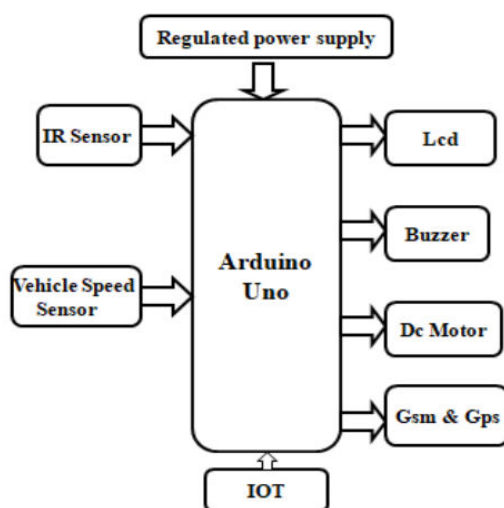

Fig1 : Block Diagram

1.GPS module :

The Global Positioning System (GPS) is a U.S.-based navigation system that provides continuous, reliable positioning, navigation,

and timing services to civilian users worldwide, free of charge. It comprises three main components: the space segment, which includes over 24 satellites orbiting approximately 20,200 km above Earth; the control segment, made up of five ground monitoring stations that oversee satellite health and position; and the user segment, consisting of commercially available GPS receivers. These receivers can determine a user's location, speed, direction, and time by capturing signals from at least three satellites for three-dimensional positioning, with a fourth satellite improving timing accuracy. GPS satellites transmit signals on two main frequencies using a spread-spectrum technique, and modern receivers can achieve accuracy within 15 meters on average. Advanced systems like the Wide Area Augmentation System (WAAS) enhance this accuracy to under three meters, while Differential GPS (DGPS) can further refine it to within three to five meters. Overall, GPS has transformed navigation, making precise location services accessible for a variety of applications, from driving to aviation.

2.WiFi Module

WiFi is a technology that enables wireless connectivity for electronic devices, allowing them to connect to the Internet via a wireless access point. Devices such as personal computers, smartphones, video game consoles, and digital media players can access the Internet when within range of a WiFi network. Typically, an access point or hotspot covers a range of about 20 meters (65 feet) indoors and even greater distances outdoors. By using multiple overlapping access points, larger areas can be covered effectively. Devices equipped with Ethernet capabilities can seamlessly connect to these



networks, facilitating Internet access in various environments—from small rooms with solid walls to expansive areas encompassing several square miles. The term "Ethernet" refers to a trademark and brand associated with the IEEE 802.11 family of standards. Today, WiFi technology is widely used, with over 700 million users and more than four million hotspots available globally. Each year, approximately 800 million new WiFi-enabled devices are sold. Those that pass interoperability certification testing may carry the "Ethernet CERTIFIED" designation, ensuring reliable connectivity across devices.

II. LITERATURE REVIEW

Several studies have explored innovative techniques for monitoring driver behavior and ensuring road safety. One notable method is the Eye Blink Monitoring (EBM) technique, which alerts drivers to drowsiness by tracking head and eye movements. This embedded system effectively identifies when a driver enters a sleep cycle, as ordinary eye blinks do not significantly impact the system's performance [1]. In another study, an Automated Speed Detection System was developed to monitor vehicle speed. When overspeeding is detected, the system captures the vehicle's license plate number and sends it via email to the toll plaza for issuing fines. This system utilizes the Doppler Effect for speed measurement and employs Digital Image Processing (DIP) to extract license information from captured images, demonstrating high effectiveness in real-world applications [2]. Further research presented a novel system that identifies speed violations using Radio Frequency

Identification (RFID), GSM, and a PIC microcontroller (18F45K22). This solution offers reliable and cost-effective real-time notifications, encouraging drivers to adhere to speed limits [3].

Additionally, a Vibration Sensor Device has been proposed to detect accidents. Upon sensing a significant vibration, the device activates and uses GPS to determine the vehicle's location, notifying patrol services for rapid response. Researchers incorporated accelerometer readings to estimate vehicle speed and detect acceleration faults, validating the sensor's accuracy through extensive testing in real driving conditions [4]. Lastly, a system aimed at detecting rash driving on highways was introduced. This approach utilizes an IR transmitter and receiver, along with a control circuit and buzzer. When a vehicle exceeds speed limits, the system triggers an alarm to alert traffic authorities, simplifying the monitoring process and reducing reliance on human intervention [5].

III. PROPOSED SYSTEM

The proposed Smart Vehicle Overspeeding Detector leverages IoT technology to provide real-time alerts regarding vehicles exceeding speed limits. This system operates without the need for manpower, automatically recording vehicle speed and wirelessly notifying the relevant authorities. The architecture of this system is designed for efficient vehicle speed detection. Speed tracking accuracy is achieved using a Speed App that employs radar technology. The system recognizes roads by referencing names from Google Maps and records vehicle speed in real-time. It cross-validates this data against designated speed limits for the specific routes. The electronic tracking



device is powered by a 12V lithium battery, providing a battery life of 5 to 10 hours. Server data will be hosted on a Windows server for six months, after which it will be archived for future use. The tracking application, compatible with Android, monitors vehicle speed and sends alerts to a designated phone number. Users can input speed limits into an online application with a secure login, which displays the vehicle's speed alongside the server time when overspeeding occurs.

IV.METHODOLOGY

The Smart Vehicle Overspeeding Detector begins by estimating the time required for a vehicle to travel from its starting point to the destination. Using this information, the system calculates the vehicle's speed through a Speed App that utilizes radar technology. This data is then wirelessly transmitted via IoT technology to the relevant authorities. The device incorporates a GPS sensing module, along with a transmitter and receiver, which work together with an electronic tracking device for accurate speed detection. Road identification relies on names from Google Maps, allowing the system to record vehicle speed in real-time and display it on an LCD screen. If an overspeeding vehicle is detected, the device activates a buzzer to alert authorities. The accuracy of speed tracking, as determined by the Speed App using radar, ranges from 40% to 80%, influenced by factors such as internet speed and connectivity.

V.CONCLUSION

This research addresses the challenge of accurate vehicle overspeed detection using IoT technology in urban environments,

supporting the development of vehicular applications. The Smart Vehicle Overspeeding Detector effectively senses driving conditions to achieve high detection accuracy, enabling timely reporting of overspeeding vehicles to prevent accidents.

Future enhancements for the proposed system may include the following developments in hardware integration, sensor interfacing, and software algorithms:

1. Solutions for detecting drunk driving.
2. Mechanisms for controlling the speed of emergency vehicles.
3. Systems for detecting wheel slip using gravity sensors.
4. Impact detection for identifying accidents.
5. Measures to prevent rash driving by disabling the spark plug.

VI.REFERENCES

- [1] Arjun K., Prithviraj and Ashwitha A. (2017), "Sensor Based Application for Smart Vehicles", International Journal of Latest Trends in Engineering and Technology, 8 (1), pp. 526-532.
- [2] Rangan P. R. (2017), "Vehicle Speed Sensing and Smoke Detecting System", International Journal of Computer Science and Engineering, pp. 27-33.
- [3] Aishwarya et al. S. R. (2015), "An IoT Based Accident Prevention & Tracking System for Night Drivers", International Journal of Innovative Research in Computer and Communication Engineering, 3 (4), pp. 3493-3499.
- [4] Malik et al. (2014), "Automated Over Speeding Detection and Reporting System", IEEE Xplore, pp. 1-7.



- [5] Shabibi L. A., Jayaraman N. and Vrindavanam J. (2014), "Automobile Speed Violation Detection System using RFID and GSM Technologies", International Journal of Applied Information Systems, Vol. 7, No. 6, pp. 24-29.
- [6] Prasanth P. and Karthikeyan U. (2016), "Effective Tracking of Misbehaviorial Driver & Over Speed Monitoring With Emergency Support", International Journal of Advanced Research in Computer Engineering & Technology, 5 (10), pp. 2527-2529.
- [7] Jain et al. M. (2015), "Detection of Over Speeding Vehicles on Highways", International Journal of Computer Science and Mobile Computing, 4 (4), pp. 613 – 619.
- [8] Isong B., Khutsoane O. and Dladlu N. (2017), "Real-time Monitoring and Detection of Drinkdriving and Vehicle Over-speeding", I.J. Image, Graphics and Signal Processing, 11, pp. 1-9.
- [9] Bhavale et al. D. M. (2016), "IOT Based Unified Approach for Women and Children Security Using Wireless and GPS", International Journal of Advanced Research in Computer Engineering & Technology, 5 (8), pp. 2325-2328.
- [10] Madhuri et al. T. (2017), "Computer Science Technology Trends in The Internet of Things (IoT) With A Proposal Of IoT Device For Vehicle And Human Safety", Proceedings of 38th IRF International Conference, Bengaluru, India.