



IMPLEMENTATION OF SOLAR PHOTOVOLTAIC SYSTEM WITH UNIVERSAL ACTIVE FILTERING CAPABILITY

¹DUDEKULA NAZEER AHMAD, ²A. MALLIKARJUNA PRASAD

¹P.G. Scholar, Branch: Department of EEE, M.Tech, Geethanjali College Of Engineering And Technology,
Kurnool, India.

Email:- nazeerahmad202@gmail.com

²Guide, Asst. Professor of EEE, Geethanjali College Of Engineering And Technology, Kurnool, India.

Email:- mallikarjunaprasad0307@gmail.com

ABSTRACT:

In this work, a novel technique based on second order sequence filter and proportional resonant controller is proposed for control of universal active power filter integrated with PV array system (UAPF-PV). Using a second order sequence filter and sampling it at zero crossing of instant of the load voltage, the active component of distorted load current is estimated which is further used to generate reference signal for shunt active filter. The proposed method has good accuracy in extracting fundamental active component of distorted and unbalanced load currents with reduced mathematical computations. Along with power quality improvement, the system also generates clean energy through the PV array system integrated to its DC-bus. The UAPF-PV system integrates benefits of power quality improvement and distributed generation. The system performance is experimentally evaluated on an experimental prototype in the laboratory under a variety of disturbance conditions such as PCC voltage fall/rise, load unbalancing and variation in solar irradiation.

KEYWORD: Voltage control, Power quality, Active filters, Shunts (electrical), Voltage fluctuations, Power conversion

5.1. INTRODUCTION

There has been an ever increasing focus on installation of renewable energy sources such as solar photovoltaic (PV) and wind energy systems with the grid. This has been facilitated due to development of reliable and efficient power converters, improved efficiency of PV panels and decreasing costs of manufacturing. However, with the increasing penetration of renewable energy sources, which are intermittent sources of energy, fluctuations in voltage at the point of common coupling (PCC), have also increased. This is particularly common in low voltage

distribution systems. Another major issue faced in modern distribution systems, is the extensive use of nonlinear power electronic systems, which draw highly distorted currents. These distorted currents cause voltage distortion at PCC depending upon the magnitude of current and grid impedance. These loads also cause losses in feeders and distribution transformers. Moreover, these loads themselves are sensitive to PCC voltage dip/rise, which causes frequent tripping and increased maintenance costs. Hence, the major requirement of modern distribution system



International Journal For Advanced Research In Science & Technology

A peer reviewed international journal

www.ijarst.in

www.ijarst.in

ISSN: 2457-0362

is the integration of renewable energy systems along with power quality improvement. In order to improve power quality, various improved quality devices based on power factor correction (PFC), have been researched upon and developed. However, these are mainly suitable at low and medium power levels and are only cost effective when developing a completely new system.

Custom power devices such as distribution static compensator (DSTATCOM), dynamic voltage restorer (DVR) and unified power quality conditioner (UPQC) which is also known as unified active power filter (UAPF), are used as retrofit solution for power quality improvement in large scale industrial systems. An integration of solar PV array along with custom power devices, provides dual solution of power quality improvement along with solar energy. A solar PV integrated distribution static compensator (PV-DSTATCOM) has been proposed. This system has dual role of generation of power from renewable sources along with compensation of load current harmonics generated due to nonlinear loads. A single phase multi-functional solar energy conversion system has been proposed. This system has combined clean energy generation and active filtering functionality for a single phase distribution system. A variable DC-link voltage grid interfaced converter for three phase supply systems has been proposed. This system apart from combining clean energy generation and active filtering has an adjustable DC link

voltage. The DC-link voltage is adjusted based on voltage at point of common coupling (PCC), which leads to an improved efficiency and good harmonic compensation of load current. While most of the research on integration of clean energy systems with active filtering, has been done on shunt compensated systems, recently there has been research into integration of distributed generation capability along with universal active power filters. The shunt active power filter has a disadvantage that it requires reactive power to regulate the voltage at the PCC. Hence, the requirement of voltage regulation and maintaining unity power factor (UPF) for grid current cannot be met simultaneously by the shunt active filter. The solar integrated universal active power filter (UAPF-PV) system regulates load voltage apart from injecting/drawing the grid current at UPF.

A (UAPF) along with PV integration, has been proposed. The UAPF system provides both voltage and current quality improvement as it has both shunt and series active power filters. Accurate and fast reference signal estimation for the shunt and series active filter, is critical for improved operation of PV-UAPF under various dynamic conditions commonly encountered in distribution system. An extraction of fundamental component of distorted signal is a major task in reference signal generation. The conventional techniques employed for the control of active filters, includes techniques known as p-q and d-q theories. However, these techniques require multiple transformations and their dynamic



performance deteriorates during load unbalanced conditions. Some of advanced techniques for extraction of fundamental component, include techniques based on least mean square technique (LMS), adaptive notch filter (ANF). These techniques are inherently single phase techniques and require at least two such structures along with mathematical operations to extract fundamental positive sequence components. In, a damped SOGI technique has been proposed for the reference signal generation for a PV system. In this technique, the fundamental active component of load current in each phase has been extracted using damped SOGI filter. In, an adaptive filter is used control of a single stage three phase UAPF. However, the filters used, are inherently single phase filters and consequently used two adaptive filters along with mathematical operations for implementing in three phase system. Another class of filters, which are inherently three phase filters and can extract fundamental positive sequence components directly are based on sequence filters, complex filters etc. Other advanced techniques for extraction of fundamental active component include, techniques based on adaptive linear element (ADALINE) and wavelet transforms. Though they have good accuracy, there is trade-off due to higher computational burden. In this work, a novel control technique is proposed for control of UAPF-PV, which is based on proportional resonant control for series active filter and second order sequence filter based control for the shunt active filter. The second order

sequence filter estimates fundamental positive sequence component of distorted load currents. The fundamental positive sequence components are sampled at appropriate instant to extract the magnitude of fundamental active component of load current. These are then used to generate reference signals for the operation of the shunt active filter. This technique has improved precision in extracting active component of distorted load current with good dynamic performance. The series active filter regulates the load voltage under PCC voltage dip and rise by introducing necessary required voltage in series with PCC voltage.

The major focus and advantages of this research work, are summarized as follows. • A multifunctional topology which integrates clean energy generation along with power quality improvement.

[1] It protects sensitive loads from PCC voltage dip/rise along with compensating nonlinear current drawn by the load.

[2] Use of second order sequence filter, which is inherently a three phase filter along with zero cross detection technique gives improved accuracy in extraction of load current active component of all three phases with a single sample and hold operation.

[3] Dynamic and steady state performances of UAPF-PV system are evaluated under conditions such as dip/rise in PCC voltage, unbalanced load removal and variation in solar irradiation intensity. The PV-UAPF system performance is

evaluated through simulation in Matlab-Simulink software.

The performance is also experimentally validated on a laboratory prototype. The system performance is validated under steady state conditions to check its compliance with the IEEE-519 standard. This prototype is then subjected to various dynamic conditions such as voltage sags/swells, solar irradiation and load unbalance to evaluate its performance under dynamic conditions.

II. CLASSIFICATION OF POWER QUALITY PROBLEMS

This IEEE defined power quality disturbances shown in this paper have been organized into seven categories based on wave shape:

1. Transients.
2. Interruptions.
3. Sag / under voltage.
4. Swell / Overvoltage.
5. Waveform distortion.
6. Voltage fluctuations.
7. Frequency variations.

III. SYSTEM DESIGN

There are two main system configurations – stand-alone and grid-connected. As its name implies, the stand-alone PV system operates independently of any other power supply and it usually supplies electricity to a dedicated load or loads. It may include a storage facility (e.g. battery bank) to allow electricity to be provided during the night or at times of poor sunlight levels. Stand-alone systems are also often referred to as autonomous systems

since their operation is independent of other power sources. By contrast, the grid-connected PV system operates in parallel with the conventional electricity distribution system. It can be used to feed electricity into the grid distribution system or to power loads which can also be fed from the grid.

It is also possible to add one or more alternative power supplies (e.g. diesel generator, wind turbine) to the system to meet some of the load requirements. These systems are then known as ‘hybrid’ systems.

Hybrid systems can be used in both stand-alone and grid-connected applications but are more common in the former because, provided the power supplies have been chosen to be complementary, they allow reduction of the storage requirement without increased loss of load probability. Figures below illustrate the schematic diagrams of the three main system types.

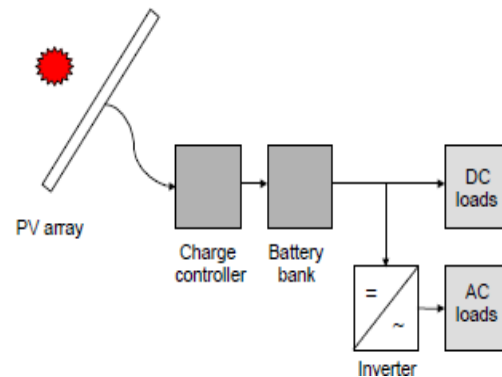

Figure 2.12. Schematic diagram of a stand-alone photovoltaic system.

IV. MATLAB & SIMULATION

RESULTS:

The performance of three phase double stage UAPF-PV system is simulated in Matlab/Simulink software. The solver used for the system, is discrete solver with

minimum step size of $1e^{-6}$. The system is tested under various dynamic conditions such as load balance, irradiation variation, voltage sag/swell etc.

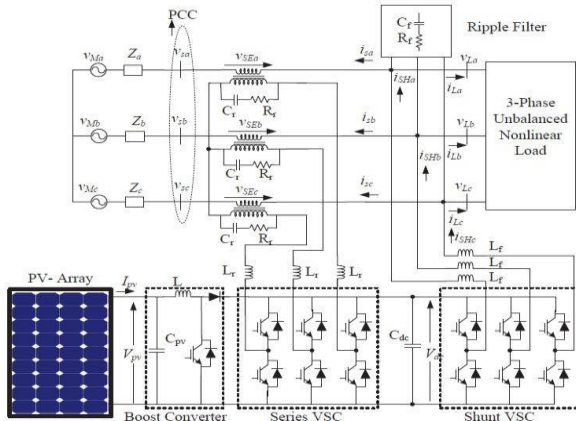

Figure 5.1. System configuration of UAPF-PV System

I.I Simulated performance of UAPF-PV System under PCC Voltage Sag/Swell

Fig.5.2 shows the performance of UAPF-PV under sags/swells in PCC voltages. The signals captured, are three phase PCC voltages v_{sabc} , load voltages (v_{labc}), series compensator voltages (v_{SEabc}), DC-link voltage (V_{dc}), grid currents (i_{sabc}), load currents (i_{Labc}), shunt compensator currents (i_{SHabc}), PV array power (P_{pv}) and PV array voltage (V_{pv}). The PV array irradiation is maintained constant at $G = 1000W/m^2$. From $t=0.65s$ to $0.7s$, the PCC voltages dips to $0.7pu$ and between $0.75s$ to $0.8s$ the PCC voltages rise to $1.3pu$. It can be observed that under both these conditions the load voltages are regulated at its desired value. The grid currents are sinusoidal and the DC link voltage is also regulated at its preset value. There is rise in the grid current in voltage sag condition and a decrease in

current during voltage swell condition in order to maintain power balance.

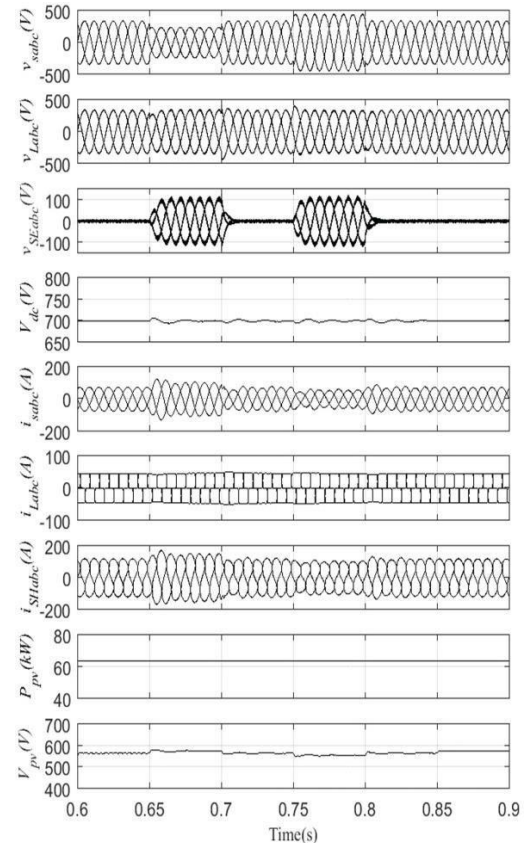

Figure 5.2 Simulated Performance of UAPF-PV under Sags and Swells in Voltages at the PCC

I.II Simulated performance of UAPF-PV System under Load Unbalance Condition

The performance of UAPF-PV system under load unbalanced condition is given in Fig.5.3. The signals shown, are three phase PCC voltages v_{sabc} , load voltages v_{labc} , DC-link voltage V_{dc} , grid currents i_{sabc} , load currents i_{Labc} , shunt compensator currents i_{SHabc} , PV array power P_{pv} and PV array voltage V_{pv} . The PV array irradiation is maintained constant at $G = 1000W/m^2$. At $t=0.6s$, the phase 'A' load is removed. It can be observed that the DC-link voltage is

regulated at its desired voltage of 700 V. There is ripple present in DC-link voltage, which is due to double harmonic component present during unbalanced loading condition. The shunt compensator of UAPF- PV system compensates for the unbalanced loading and it maintains the PCC currents balanced and sinusoidal within couple of cycles.

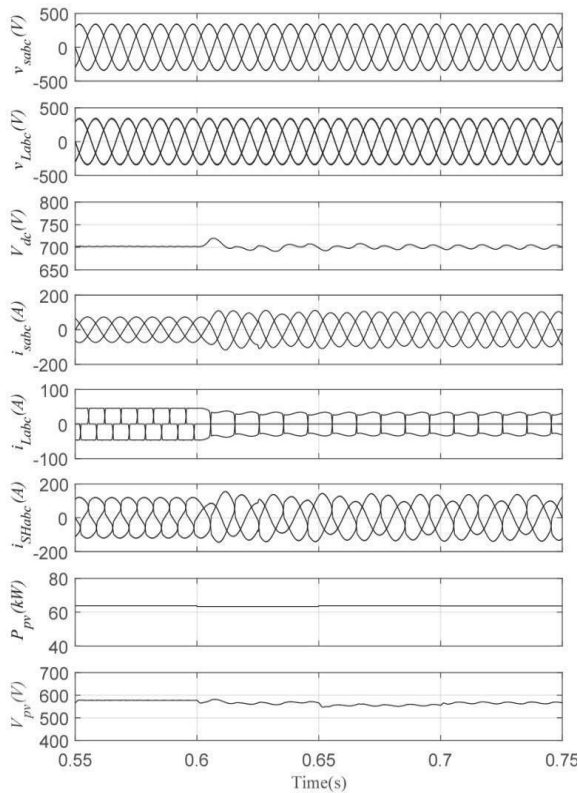

Figure 5.3 Simulated performance of UAPF-PV System under Load Unbalance Condition

Simulated Performance of UAPF-PV System at Irradiation Variation Condition

The performance of UAPF-PV system under irradiation variation condition is presented in Fig.5.4 The signals shown, are three phase PCC voltages v_{sabc} , load voltages

v_{labc} , DClink voltage V_{dc} , grid currents i_{sabc} , load currents i_{Labc} , shunt compensator currents i_{SHabc} , PV array power P_{pv} and PV array voltage V_{pv} and irradiation intensity $G(W/m^2)$. From $t=0.6s$ to $t=0.65s$, the solar irradiation is varied from $1000W/m^2$ to $500W/m^2$. Due to reduction in the PV power generated, there is reduction in the current injected into the grid. The system DC-link voltage is regulated at its desired value of 700 V.

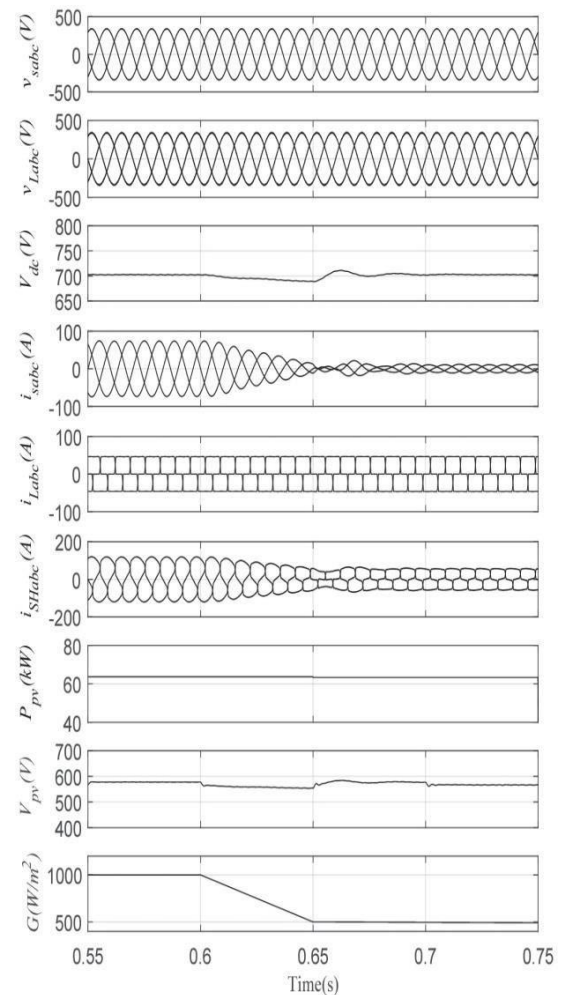

Figure 5.4 Simulated Performance of UAPF-PV System at Irradiation Variation Condition



CONCLUSION:

The performance of a novel control technique for solar PV system with universal active filtering, has been evaluated. The fundamental positive sequence components of nonlinear load currents are extracted using a second order sequence filter along with a zero cross detection technique. The series active filter is controlled using a proportional resonant controller implemented in $\alpha - \beta$ domain along with feed forward component. The system performs satisfactorily under disturbances such as PCC voltage dip/rise, changes in solar radiation and load disturbances. Apart from improving power quality, the system also supplies power from a PV array into the grid. A comparison of the proposed control shows that the system has improved performance as compared to conventional control techniques with low computational burden. The system integrates distributed generation along with enhancing power quality of distribution system.

FUTURE SCOPE

This project is also further extended for the steady state performance of the system. The harmonic spectra and total harmonic distortion of the grid current and load current. It can be observed that while the load current total harmonic distortion (THD) is 28.61%, the grid current THD is 1.69% which is within the limits prescribed in the IEEE-519 standard. The system proposed is a double stage system, which can be typically used for rooftop PV system of large commercial buildings and households. The second order sequence filter used is

inherently a three phase filter and directly gives the fundamental balanced positive sequence component of the unbalanced nonlinear load currents. The filters used are inherently single phase filters. Hence, two such adaptive filters are used along with mathematical operations to extract the fundamental positive component of the nonlinear load currents. As the system is a double stage PV system, the DC-link voltage is constant irrespective of fluctuations in MPP voltage of PV array, which varies with irradiation intensity. The DC-link voltage varies with the MPP voltage of PV array and as a consequence the system has to be designed considering this variation in DC-link voltage. The series controller is implemented using a proportional resonant controller in $\alpha - \beta$ frame and has reduced mathematical calculations involved as compared to PI controller in d-q domain.

REFERENCES:

- M. Qasim and V. Khadkikar, "Adaline based control strategy for three-phase three-wire upqc system," in 2014 16th International Conference on Harmonics and Quality of Power (ICHQP), May 2014, pp. 586–590.
- B. Singh, A. Chandra, K. A. Haddad, Power Quality: Problems and Mitigation Techniques. London: Wiley, 2015.
- Y. Singh, I. Hussain, S. Mishra, and B. Singh, "Adaptive neuron detection-based control of single-phase spv grid integrated system with active filtering," IET Power Electronics, vol. 10, no. 6, pp. 657–666, 2016.



- S. Singh, B. Singh, G. Bhuvaneshwari, and V. Bist, "A power quality improved bridgeless converter-based computer power supply," *IEEE Transactions on Industry Applications*, vol. 52, no. 5, pp. 4385–4394, Sept 2016.
- M. Badoni, A. Singh, and B. Singh, "Comparative performance of wiener filter and adaptive least mean square-based control for power quality improvement," *IEEE Trans. Ind. Electron.*, vol. 63, no. 5, pp. 3028–3037, May 2016.
- B. Singh, S. Kumar, and C. Jain, "Damped-SOGI based control algorithm for solar pv power generating system," *IEEE Trans. Ind. Appl.*, vol. 53, no. 3, pp. 1780–1788, May 2017.
- S. J. Pinto, G. Panda, and R. Peesapati, "An implementation of hybrid control strategy for distributed generation system interface using xilinx system generator," *IEEE Transactions on Industrial Informatics*, vol. 13, no. 5, pp. 2735–2745, Oct 2017.
- S. Devassy and B. Singh, "Design and performance analysis of three phase solar PV integrated UPQC," *IEEE Transactions on Industry Applications*, vol. PP, no. 99, pp. 1–1, 2017.
- B. Singh, M. Kandpal, and I. Hussain, "Control of grid tied smart pvstatcom system using an adaptive technique," *IEEE Transactions on Smart Grid*, vol. 9, no. 5, pp. 3986–3993, Sept 2018.
- C. Jain and B. Singh, "An adjustable dc link voltage-based control of multifunctional grid interfaced solar pv system," *IEEE Journal of Emerging and Selected Topics in Power Electronics*, vol. 5, no. 2, pp. 651–660, June 2017.
- R. Chilipi, N. A. sayari, K. H. A. Hosani, and A. R. Beig, "Adaptive notch filter based multipurpose control scheme for grid-interfaced threephase four-wire dg inverter," *IEEE Trans. Ind. Appl.*, vol. PP, no. 99, pp. 1–1, 2017.
- A. B. Shitole, H. M. Suryawanshi, G. G. Talapur, S. Sathyan, M. S. Ballal, V. B. Borghate, M. R. Ramteke, and M. A. Chaudhari, "Grid interfaced distributed generation system with modified current control loop using adaptive synchronization technique," *IEEE Trans. Ind. Electron.*, vol. 13, no. 5, pp. 2634–2644, Oct 2017.
- N. Kumar, I. Hussain, B. Singh, and B. K. Panigrahi, "Framework of maximum power extraction from solar pv panel using self predictive perturb and observe algorithm," *IEEE Transactions on Sustainable Energy*, 2017, Early Access
- S. Devassy and B. Singh, "Implementation of solar photovoltaic system with universal active filtering capability," in *2018 IEEMA Engineer Infinite Conference (eTechNxT)*, March 2018, pp. 1–7.
- S. Devassy and B. Singh, "Control of a solar photovoltaic integrated universal active power filter based on a discrete adaptive filter," *IEEE Transactions on Industrial Informatics*, vol. 14, no. 7, pp. 3003–3012, July 2018.