



## DESIGN AND DEVELOPMENT OF SMART HELMET FOR SAFETY APPLICATIONS

<sup>1</sup>JANGAM HARIKRISHNA, <sup>2</sup>ATHOTA SYAM KUMAR

<sup>1</sup>M.Tech scholar, Dept of ECE, Nalanda Institute of Engineering Technology, Sattenapalle, Guntur District, Andhra Pradesh

<sup>2</sup>Assistant Professor, Dept of ECE, Nalanda Institute of Engineering Technology, Sattenapalle, Guntur District, Andhra Pradesh

**ABSTARCT:** In this paper the design and development of Smart Helmet for safety applications is done. Basically Accidents are increasing day by day all over the world. Firstly, when alcohol is detected then engine will be stopped and an SMS & location of that vehicle is send to the corresponding police station. When accident is occurred then accident detection sensor will be detected, an SMS and location of that person send to the nearby hospital. When driver will be in sleepy condition then eye blink sensor will be detected and stops the motor of the vehicle. At last this gives effective output. At last Effective output is obtained by using this project.

**KEY WORDS:** ARM, Power Supply, LCD Display, GSM, GPS, Accident detection sensor, Eye Blink Sensor, Alcohol Detection sensor.

### I.INTRODUCTION

Street security is a significant issue these days. As indicated by the WHO, street mishaps caused an expected 1.25 million passing's worldwide in the year 2013. The greater part of the mishaps happening cause extreme passing's because of rash driving, not utilizing security measures. Numerous individuals don't understand that wearing a protective cap decreases the danger of a serious cerebrum injury or even passing (now and again) [1]. Throughout a fall or crash, the vast majority of the effect vitality is consumed by the cap as opposed to your head and mind. Individuals are charged when they don't put on their head protectors, yet they totally disregard the hugeness of it and cost their life for it. We've figured out how to make protective caps mandatory who is riding a bicycle. A simple, cost-effective,

Agreeable way where the rider's security is given most extreme need. In this venture, the bicycle begins just when the rider puts on his head protector. Here, the RF transmitter is available inside the head protector and just when the individual wears it, the association is set up and the sign is sent to the RF beneficiary present in the bicycle which begins the start or beginning of the bicycle [2-3]. So the bicycle won't start except if the individual puts on the head protector.

GPS, GSM module and Accelerometer are likewise introduced in the protective cap which causes us know when an abrupt mishap happens (by checking accelerometer) and sends the area to our family. A global positioning framework is empowered and can be observed (if



required) if the individual is being trailed by an obscure individual or any such dangers. Thusly, the individual will never overlook or neglect to wear the head protector and maintains his wellbeing in a simple and agreeable way.

## II. LITEARTURE SURVEY

Nimisha Chaturvedi proposed a framework with GPS and GSM for mishap location. It utilizes a catch sensor to distinguish a mishap and if the mishap happens a bell is turned on furthermore, area will be sent to the contact list spared in EEPROM. On the off chance that the rider presses the reset button the sending of the message is ended. Prof. K. Y. Rajput. proposed a framework which utilizes the IR sensor to check whether the head protector is worn or not. It utilizes a Gas sensor for liquor discovery. In this framework, switches are set on the bicycle. On the off chance that the mishap happens and switches have squeezed the data alongside area will be sent to crisis contacts utilizing GPS and GSM [4-5].

Manjesh N exhibited a shrewd protective cap which has vibration sensors in it. At the point when the rider accidents and protective cap hits the ground the sensors will detect and GPS area is removed and sent to contacts by means of GSM. Shrutika S proposed a framework where power sensor is utilized to recognize the protective cap. GPS and GSM sensors are utilized to send the area to the contacts when the mishap happens.

As indicated by the ongoing Research paper in 2016 named '2 Helmet utilizing GSM and GPS innovation for mishap identification and detailing framework', The creator exceptionally built up this undertaking to improve the wellbeing of the bikers. The target of this venture is to examine and comprehend the idea of RF transmitter and RF collector circuit. The task utilizes ARM7, GSM and GPS module. The venture likewise utilizes bell for sign reason. At whatever point the mishap will happen then mishap spot will be note down and data will convey on the enlisted portable number.

The significant burden of this task is they are not utilizing any show gadget for indicating the current status. Likewise the expense of protective cap is still high since head protector is intended for just one reason. As per the Research paper in 2015 named 'Microcontroller based savvy wear for driver security', In this paper creator has talked about on the speed of the vehicle. In this application the venture will screen the zones wherein the vehicle will be passing. On entering any preventative territories like schools, medical clinics, and so forth the speed of the vehicle will be controlled to a predefined limit. LCD is utilized for indicating the different sorts of messages in the wake of wearing the head protector. The creator has worked distinctly on the marvel of mishap which is by and large occurs because of alcoholic and drive. However, as we realize that the mishap in the territory isn't occurs just due to devouring liquor yet

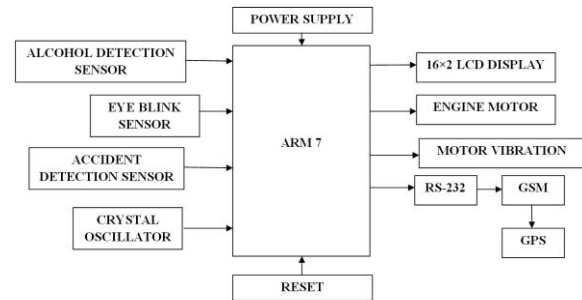
in addition different boundaries like speed are likewise dependable.

As per the Research paper in 2016 named 'Savvy Helmet', In this paper the fundamental goal of creator is to constrain the rider to wear the head protector. In this serious world one of the overview says that the passing trolls because of engine bicycle mishaps are expanding step by step out of which the majority of these setbacks happens as a result of the nonattendance of head protector. Traffic police can't cover far off streets of city. That is the reason over essential goal is to make the use of the head protector for bikes "necessary". Thus, nobody other than the proprietor himself, who doesn't have "secret word" which would have been made by the proprietor, can utilize the bicycle. In this creator has proposed the element that the bicycle won't start except if the bicycle rider doesn't wear the head protector. The different this module essentially manages the checksum of rider in the event that he is wearing the protective cap or not on the lead position to accomplish this ultrasonic sensor is been utilized. based on this the sign are been sent to the following module voice acknowledgment module use for verification reason.

### III. PROPOSED SYSTEM

The below diagram shows the architecture of proposed system. Firstly, when alcohol is detected then engine will be stopped and an SMS & location of that vehicle is send to the corresponding police station. When accident is occurred then accident detection sensor will be detected, an SMS and location of that

person send to the nearby hospital. When driver will be in sleepy condition then eye blink sensor will be detected and stops the motor of the vehicle. At last this project gives effective output. The description of each component is given below.



**Fig. 1: PROPOSED SYSTEM**

#### A. ARM

A 128-piece wide memory interface and stand-out stimulating specialist building configuration authority 32-piece code execution at the most extraordinary clock rate. For isolate code size applications, the alternative 16-piece Thumb mode diminishes code by in excess of 30 percent with immaterial execution discipline.

#### B. CRYSTAL OSCILLATOR

An oscillator gives a wellspring of repetitive A.C. movement over its yield terminals without requiring any commitment (beside a D.C. gracefully). The banner delivered by the oscillator is as a general rule of consistent adequate. The wave shape and adequacy are appearing by the arrangement of the oscillator circuit and choice of section regards. The repeat of the yield wave may be fixed or variable, dependent upon the oscillator structure.

#### C. POWER SUPPLY

Power supplies of late have largely improved in unwavering quality that may, on the grounds they need to deal with impressively higher voltages and flows than any or the vast majority of the hardware they gracefully, and regularly the most exposed to disappointment of any piece of an electronic framework. Present day power supplies have additionally expanded the incredibly their multifaceted nature, and can flexibly entirely stable yield voltages controlled by criticism frameworks. Many force gracefully circuits likewise contain programmed security circuits to forestall danger over voltage or over current circumstances.

### D. GSM

Global System for Mobile Communications (GSM) modems are specific kinds of modems that work on membership based remote systems, like a cell phone. A GSM modem acknowledges Subscriber Identity Module (SIM) card, and essentially acts like a cell phone for a PC. Such a modem can even be a devoted cell phone that the PC utilizes for GSM arrange capacities.

### E. RS-232

RS-232 is a standard convention utilized for sequential correspondence; it is utilized for associating personal computer and its fringe gadgets to permit sequential information trade between them. As it acquires the voltage for the way utilized for the information trade between the gadgets.

### F. LCD DISPLAY

LCD is utilized to show the information. 16x2 is the LCD that has been utilized for example 16 characters in 1 line; all out 2 lines are there. It requires +5V to work. It is associated with port 2 of microcontroller

### G. ALCOHOL DETECTION SENSOR

Firstly, when alcohol is detected then engine will be stopped and an SMS & location of that vehicle is send to the corresponding police station.

### H. ACCIDENT DETECTION SENSOR

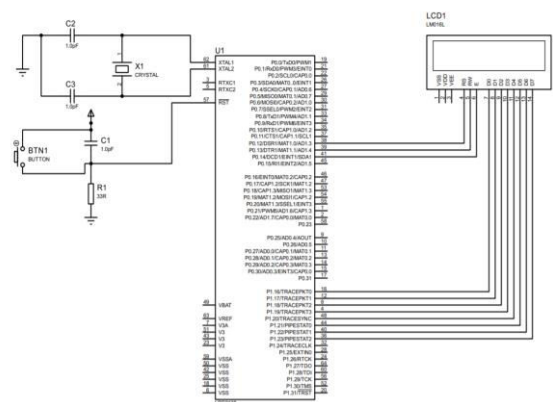
When accident is occurred then accident detection sensor will be detected, an SMS and location of that person send to the nearby hospital.

### I. EYE BLINK SENSOR

When driver will be in sleepy condition then eye blink sensor will be detected and stops the motor of the vehicle.

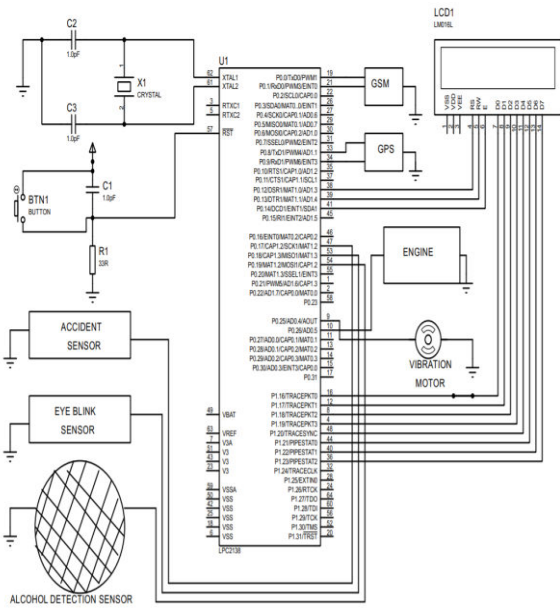
## IV. RESULT

The below figure (2) shows the basic circuit diagram of proposed system.



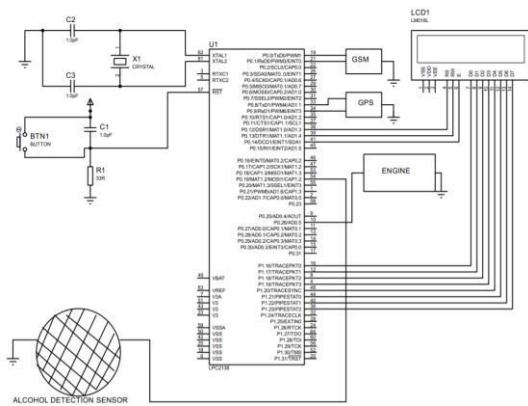
**Fig. 2: BASIC CIRCUIT DIAGRAM**

The below figure (3) shows the complete circuit diagram of proposed system.



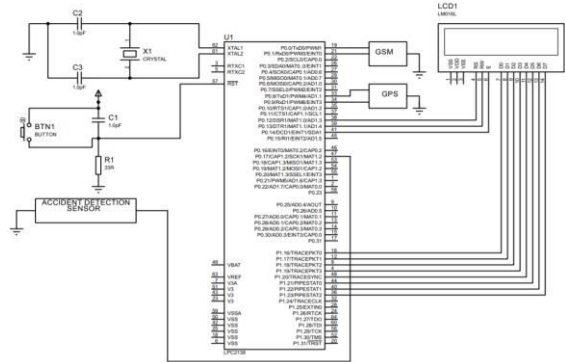
**Fig. 3: CIRCUIT DIAGRAM OF PROPOSED SYSTEM**

The below figure (4) shows the circuit diagram when alcohol detection system is detected.

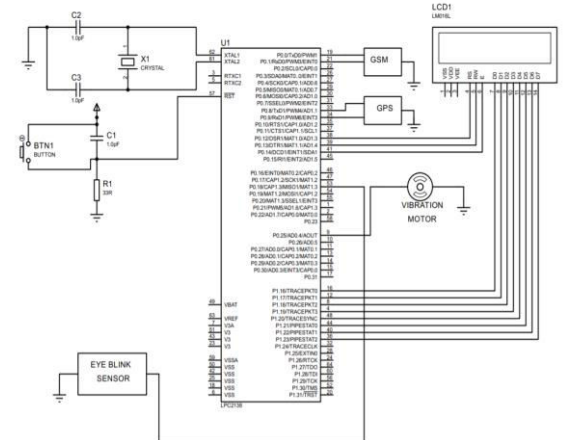


**Fig. 4: WHEN ALCOHOL DETECTION SENSOR IS ACTIVATED**

The below figure (5) shows the circuit diagram when Accident Detection sensor is activated.



**Fig. 5: WHEN ACCIDENT DETECTION SENSOR IS DETECTED**



**Fig. 6: WHEN EYE BLINK SENSOR IS ACTIVATED**

## V. CONCLUSION

Hence in this the design and development of Smart Helmet for safety applications was successfully done. Firstly, when alcohol is detected then engine will be stopped and an SMS & location of that vehicle is send to the corresponding police station. When accident is occurred then accident detection sensor will be detected, an SMS and location of that person send to the nearby hospital. When driver will be in sleepy condition then eye blink sensor will be detected and stops the



motor of the vehicle. At last this project gives effective output. At last Effective output is obtained by using this project.

## VI. REFERENCES

[1] Automatic Vehicle Accident Detection and Messaging System Using GSM and GPS Modem Nimisha Chaturvedi<sup>1</sup>, Pallika Srivastava, International Research Journal of Engineering and Technology (IRJET) Volume: 05 Issue: 03 | Mar-2018 [www.irjet.net](http://www.irjet.net)

[2] SMART HELMET Prof. K. Y. Rajput<sup>1</sup>, Gunprabh Chadha<sup>2</sup>, Brij Kanodia<sup>3</sup> and Vishal Lakhani. International Research Journal of Engineering and Technology (IRJET) Volume: 03 Issue: 02 | Feb-2016

[3] Smart Helmet Using GSM & GPS Technology for Accident Detection and Reporting System Manjesh N<sup>1</sup>, Prof. Sudarshan Raj<sup>2</sup> International Journal of Electrical and Electronics Research Vol. 2, Issue 4, pp: (122-127)

[4] Smart Helmet: For Driver Safety 1 Shrutika S. Ghosalkar, 2 S. L. Nalbalwar, 3n.S.Jadhav Proceedings of 74 th IRF International Conference.

[5] Prudhvi Raj R, Sri Krishna Kanth, Bhargav Aditya Bharath K, (2014) "Smart-tec Helmet" Electrical and Electronics Engineering, GITAM University, Rushikonda, Visakhapatnam, India. Advance in Electronic and Electric Engineering 4: 493-498.

[6] Behr, C.J., Kumar, A., Hancke, G.P " A Smart Helmet for Air Quality and Hazardous Event Detection for the Mining

Industry" Proceedings of the IEEE International Conference on Industrial Technology 2016- May, 7475079, pp. 2026-2031

[7] Sreenithy Chandran, Sneha Chandrasekar, N Edna Elizabeth "Konnnect: An Internet of Things (IoT) based smart helmet for accident detection and notification" 2016 IEEE Annual India Conference (INDICON)

[8] Rashmi Vashisth, Sanchit Gupta, Aditya Jain, Sarthak Gupta, Sahil, Prashant Rana "Implementation and analysis of smart helmet" 2017 4th International Conference on Signal Processing, Computing and Control (ISPCC)

[9] D. Selvathi, P. Pavithra, T. Preethi "Intelligent Transportation System for Accident Prevention and Detection" 2017 International Conference on Intelligent Computing and Control Systems (ICICCS)

[10] Archana D, Boomija G, Manisha J, Kalaiselvi V. K. G. "Mission On! Innovations in Bike Systems to Provide a Safe Ride Based on IOT " 2017 2nd International Conference on Computing and Communications Technologies (ICCCT)