



## APPLICATION OF RFID TECHNOLOGY FOR SOLVING VEHICLE EMISSION IN CITIES ON INTERNET OF THINGS

**Mr. G Anil Kumar <sup>1</sup>, Mr. T Manoj Kumar <sup>2</sup>**

<sup>1,2</sup>Assistant Professor, Dept. Of ECE, A.M.Reddy Memorial College of Engineering and  
Technology, Narasaraopet

### ABSTRACT

The proportion of air pollution which is caused by the cars is increasing. In order to solve this serious problem, many countries and regions have already presented a series of emissions standards, meanwhile some methods has been developed, include update motor engine or improve the quality of the gasoline. However, these actions have not brought about a striking effect as we expect. There are also some situations to fail implement these emissions standards. In this paper, a wireless inspection and notification system (WINS) through the concept of Internet of Things (IoT) is proposed. By applying the system, it is possible to smoothly realize a green traffic network. In this system, Radio frequency identification (RFID) technology as a low cost and mature wireless communication method is adopted to collect and transmit emissions information of vehicles. Moreover, The RFID devices need to be installed on the traffic lights so that reliable reading of emissions signals from a vehicle can be interrogated when the vehicles stop in front of the red light.

### INTRODUCTION

Urbanization and rapid industrialization have led to a significant rise in vehicle emissions, contributing to severe air pollution in cities. Traditional methods of monitoring emissions and controlling traffic congestion are often ineffective due to their reliance on manual enforcement and outdated infrastructure. The integration of modern technologies like RFID (Radio Frequency Identification) and IoT (Internet of Things) can offer a more efficient, automated approach to managing vehicle emissions and traffic flow in smart cities.

RFID technology plays a crucial role in tracking vehicle movements and monitoring emissions in real time. By installing RFID tags on vehicles and strategically placing RFID readers across the city, authorities can collect accurate data on vehicle emissions and traffic patterns. This data can then be processed and analyzed to identify high-pollution zones, enabling better enforcement of environmental regulations and policies.

To further enhance efficiency, the Maximum Spanning Tree (MST) algorithm is used to optimize traffic networks. This algorithm helps in identifying key roads that should be prioritized for traffic management, reducing congestion in high-emission areas. By rerouting traffic dynamically and minimizing travel delays, the MST algorithm ensures smoother transportation, thereby decreasing fuel consumption and emissions.

By integrating RFID, MST algorithms, and IoT, this project proposes a smart and data-driven approach to urban traffic and pollution management. Real-time monitoring, automated data analysis, and optimized traffic routing can significantly reduce emissions, improve air quality, and contribute to the development of sustainable smart cities. This innovative solution can serve as a model for cities worldwide.

Block Diagram

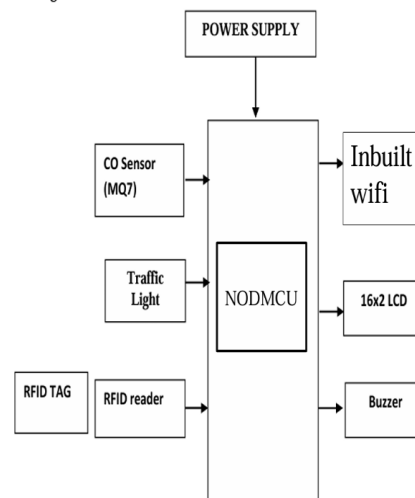

Figure.1 Block Diagram

## LITERATURE SURVEY

Air pollution caused by vehicle emissions is a major concern that demands effective monitoring and control measures. Traditional approaches, such as manual inspections and fuel quality improvements, have proven insufficient in significantly reducing pollution levels. As a result, researchers have turned to advanced technologies like RFID and IoT to develop efficient emission monitoring systems.

RFID-based monitoring systems utilize RFID tags and readers to track vehicle emissions automatically, eliminating the need for manual inspections. This enables real-time data collection, allowing authorities to implement pollution control measures more effectively. Additionally, IoT sensors play a crucial role in air quality monitoring by detecting high-emission areas and generating data-driven insights for better environmental management. Several studies highlight the advantages of integrating RFID with IoT for emission monitoring. These technologies provide a cost-effective and scalable solution for tracking pollution levels while minimizing human intervention. Moreover, cloud-based data storage and analytics enhance decision-making processes, enabling authorities to take immediate action against high-emission vehicles.

## PROPOSED SYSTEM

The proposed system is designed to monitor and regulate vehicle emissions using RFID technology and IoT-based real-time data analysis. The system consists of RFID readers and tags placed at key checkpoints to detect passing vehicles and retrieve their emission data. Additionally, IoT sensors are integrated to analyze pollution levels, ensuring accurate emission monitoring. Edge devices serve as local processing units, filtering and preprocessing data before transmitting it to the cloud, thereby optimizing network efficiency and reducing latency. This automated system eliminates manual inspections, enabling seamless and precise monitoring of vehicle emissions.

The software components of the system include an IoT cloud server for managing real-time data collection and processing, RFID processing software for secure vehicle identification,

and an emission analysis algorithm that compares measured emissions against predefined environmental standards. A centralized database management system records emission history and enforcement actions. Communication is established through wireless protocols like Wi-Fi, GSM, or LoRaWAN, facilitating efficient data transmission from RFID checkpoints to the cloud. Additionally, mobile and web-based notification systems alert vehicle owners and regulatory authorities about emission violations, ensuring compliance with environmental regulations.

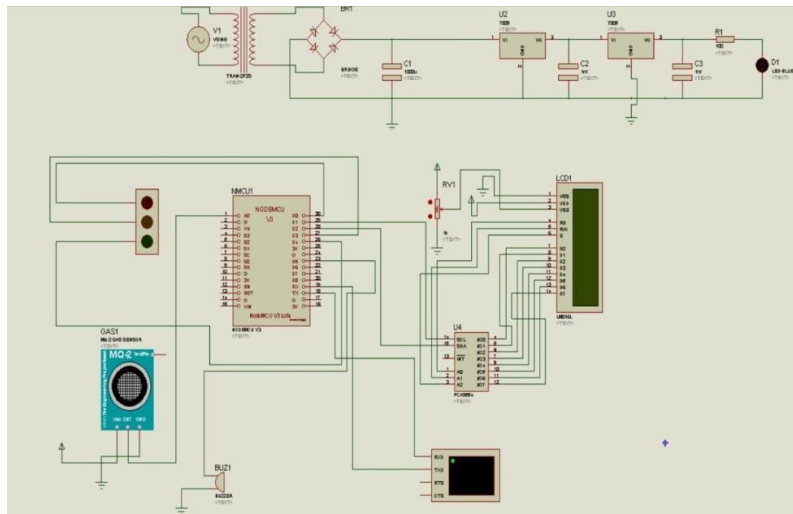

Figure.2 Schematic Diagram

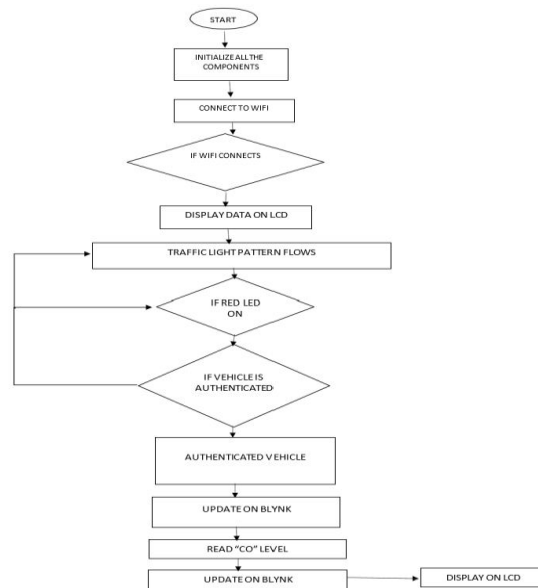

Figure.3 Flow Chart

## RESULTS

The implemented RFID-based vehicle emission monitoring system using IoT has been successfully tested. The prototype consists of an EM-18 RFID reader, RFID tags, a gas sensor module, microcontroller, power circuit, and LCD display. The system accurately scans vehicle RFID tags and detects emission levels, displaying relevant data on the LCD screen.

The EM-18 RFID reader successfully scans vehicle tags. The image below shows two RFID cards used for testing, which contain unique ID numbers. The system correctly identifies and reads these IDs, ensuring vehicle authentication and emission tracking.

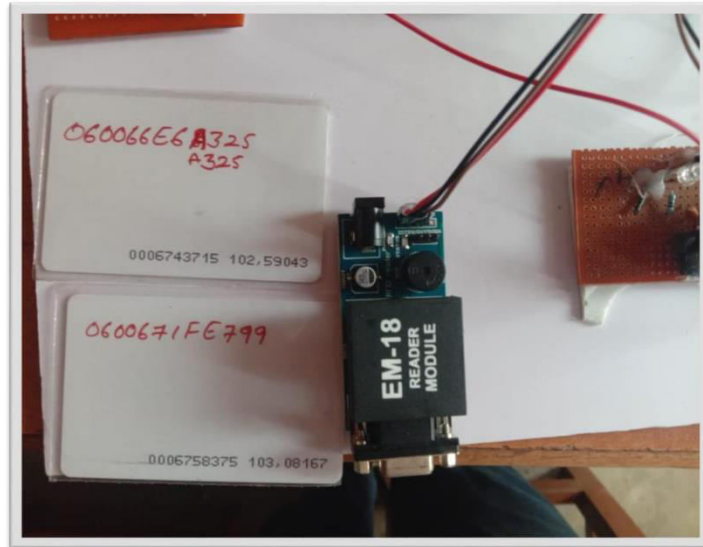

Figure.4 RFID Tags And Reader

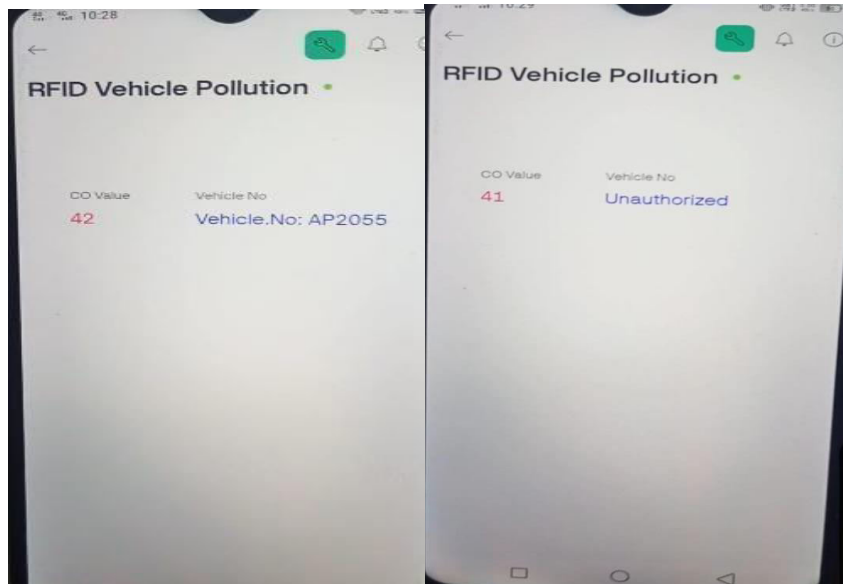

Figure.5 Authorized with CO value and Unauthorized vehicle on Blynk

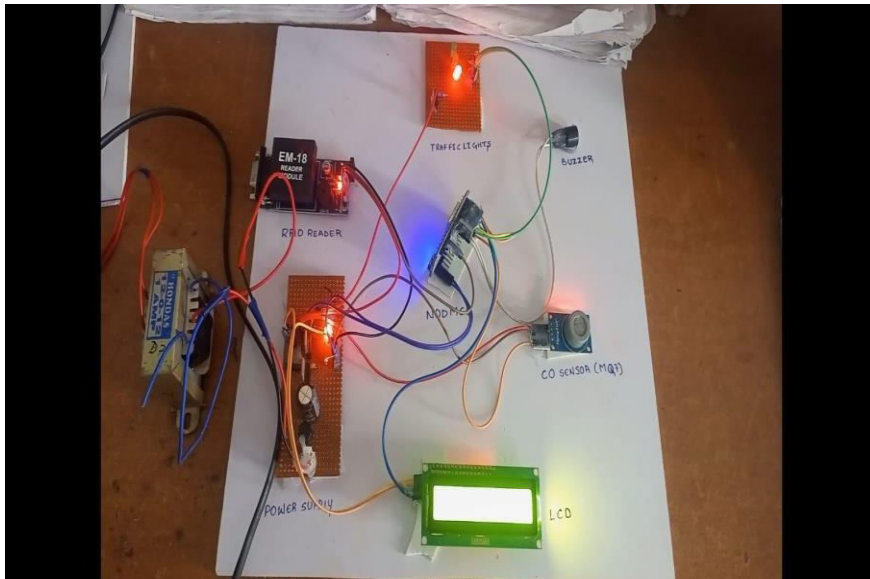

Figure.6 Working Kit

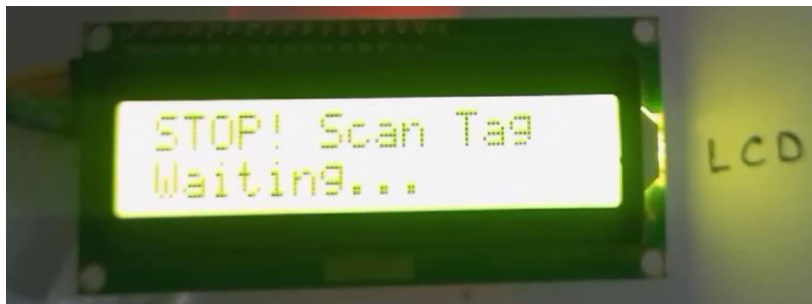

Figure.7 Scan the Vehicle tag while Red signal



Figure.8 unauthorized vehicle





## ADVANTAGES

- Real-Time Monitoring
- Cost-Effective Solution
- Automation and Efficiency
- Integration with IoT and Smart Cities
- Environmentally Friendly
- Improved Law Enforcement
- Secure and Reliable Data Collection

## APPLICATIONS

- Smart Cities and Urban Planning.
- Traffic Management Systems
- Environmental Monitoring Agencies
- Automated Toll Collection and Emission Checks
- Public Transportation Monitoring
- Industrial and Commercial Fleet Management

## CONCLUSION

RFID technology provides an advanced and efficient approach to tackling vehicle emissions. By integrating RFID with emission monitoring systems, authorities can automate compliance checks, enforce regulations, and improve urban air quality. The seamless collection of real-time data allows for informed decision-making and timely interventions, reducing overall pollution levels.

The success of RFID-based emission control requires collaboration between governments, businesses, and the public. Investment in necessary infrastructure, along with well-defined policies and incentives, can drive widespread adoption and effectiveness. RFID systems can not only detect high-emission vehicles but also encourage cleaner transportation practices through data-driven insights and targeted policies.

As urbanization and vehicle numbers continue to rise, the role of RFID in sustainable transport management becomes even more crucial. Future developments in RFID, coupled with IoT and AI advancements, can further optimize emission control strategies, ensuring long-term environmental sustainability and improved public health. Embracing RFID in emission management represents a progressive step towards achieving greener and smarter cities worldwide.

One of the major advantages of this system is its ability to reduce human intervention and provide automated monitoring, making it more accurate and reliable than traditional emission testing methods.

## FUTURE SCOPE

1. **Expansion to Smart Cities:** RFID technology can be incorporated into smart city initiatives, enabling more efficient urban planning and pollution control measures. By integrating RFID with intelligent traffic systems, cities can optimize traffic flow, reduce congestion, and lower vehicle emissions in high-density areas.



2. **Development of Dynamic Tolling Systems:** RFID-based toll systems can be enhanced to charge higher fees for high-emission vehicles, incentivizing the adoption of cleaner vehicles. This system can dynamically adjust toll fees based on real-time emission levels, discouraging the use of highly polluting vehicles and promoting eco-friendly alternatives.

## REFERENCES

1. Agarwal, A., & Mishra, R. (2013). RFID Technology: Concepts, Methodologies, Tools, and Applications. IGI Global.
2. Dobkin, D. M. (2012). The RF in RFID: Passive UHF RFID in Practice. Newnes.
3. Mallick, T. (2020). GSM-Based Embedded System Design for Environmental Monitoring. Springer.
4. Abhishek, T., & Ranjan, P. (2018). "Design and Implementation of an RFID-Based Pollution Monitoring System." International Journal of Engineering Research & Technology (IJERT), 7(3), 156-162.
5. Sharma, S., & Kumar, A. (2019). "Application of IoT in Smart Environmental Monitoring Systems." International Journal of Smart Technology and Security, 4(1), 45-52.
6. Kumar, S., & Gupta, R. (2017). "RFID and IoT-Based Vehicle Emission Monitoring System." International Journal of Embedded Systems and Applications, 5(2), 89-97.
7. Texas Instruments. (2021). "RFID Systems in Vehicle Pollution Control." Retrieved from [www.ti.com](http://www.ti.com)
8. Arduino Official Documentation. "Using RFID Modules with Arduino." Retrieved from [www.arduino.cc](http://www.arduino.cc)
9. SIMCom Wireless Solutions. "SIM800L GSM Module Datasheet." Retrieved from [www.simcom.com](http://www.simcom.com)
10. Espressif Systems. (2020). "Using Microcontrollers for IoT-Based Monitoring." Retrieved from [www.espressif.com](http://www.espressif.com)
11. U.S. Patent No. 8,495,428. (2013). "RFID-Based Emission Control and Monitoring System."
12. IEEE Conference Paper: Jadhav, R., & Patil, S. (2021). "Implementation of RFID and IoT-Based Pollution Control System." Proceedings of IEEE IoT Symposium, 25(4), 99-105.
13. International Conference on Embedded Systems. (2022). "Advancements in IoT-Based Vehicle Emission Monitoring Technologies."
14. Gartner Report. (2023). "Trends in Smart City Pollution Monitoring Using IoT and RFID."