



## Construction and Performance Investigation of Three -Phase Solar PV and Battery Energy Storage System Integrated UPQC

**Mrs. E Gowthami, G. Jahnvi, J. Anitha, K. Venkatesh, P. Madhan Mohan, L.  
Chadrakanth Naidu**

Assistant Professor, Department of Electrical & Electronics Engineering  
Rise Krishna Sai Prakasam Group of Institutions  
(208A1A0206), Department of Electrical and Electronics Engineering  
Rise Krishna Sai Prakasam Group of Institutions  
(208A1A0209), Department of Electrical and Electronics Engineering  
Rise Krishna Sai Prakasam Group of Institutions  
(218A5A0219), Department of Electrical and Electronics Engineering  
Rise Krishna Sai Prakasam Group of Institutions  
(208A1A0234), Department of Electrical and Electronics Engineering  
Rise Krishna Sai Prakasam Group of Institutions  
(208A1A0229), Department of Electrical and Electronics Engineering  
Rise Krishna Sai Prakasam Group of Institutions

### ABSTRACT

This project focuses on the construction and performance investigation of a Three-Phase Solar PV and Battery Energy Storage System integrated with a Unified Power Quality Conditioner (UPQC). The integration of renewable energy sources, such as solar photovoltaic (PV) systems, with battery energy storage systems (BESS) and UPQC technology aims to address key challenges in modern power systems, including voltage sags, harmonics, and power quality issues. The project involves the design, implementation, and evaluation of the integrated system to optimize its performance in real-world scenarios. Through comprehensive performance investigation and analysis, the project aims to enhance renewable energy integration, improve power quality, increase grid resilience, and optimize system performance.

**Keywords:** Three-Phase, Solar PV, Battery Energy Storage System, Unified Power Quality Conditioner (UPQC), Renewable Energy Integration, Power Quality Issues, Grid Resilience

### INTRODUCTION

The global energy landscape is undergoing a profound transformation, driven by the increasing adoption of renewable energy sources and the growing demand for sustainable energy solutions. In response to the challenges posed by climate change and the depletion of fossil fuel reserves, governments, industries, and communities are increasingly turning to renewable energy technologies to meet their energy needs while reducing carbon emissions and mitigating environmental impacts [1]. Among the various renewable energy sources, solar photovoltaic (PV) systems have emerged as one of the most promising solutions for clean and sustainable power generation [2].

Solar PV systems harness the abundant and freely available energy from the sun to convert sunlight into electricity, offering a reliable and renewable source of power [3]. However, despite their numerous benefits, solar PV systems also present challenges related to intermittency, variability, and grid integration [4]. The intermittent nature of solar energy generation can lead to fluctuations in power output, which may pose challenges for grid stability and reliability [5]. Additionally, solar PV systems are susceptible to environmental factors such as cloud cover and

shading, which can further exacerbate variability in power generation [6]. To address these challenges and maximize the potential of solar PV systems, there is a growing need for innovative energy storage solutions that can store excess energy during periods of high generation and discharge it during times of low generation [7]. Battery energy storage systems (BESS) have emerged as a key technology for enabling the integration of renewable energy sources like solar PV into the grid [8]. By storing surplus energy and releasing it when needed, BESS can help smooth out fluctuations in power output, improve grid stability, and enhance the reliability of renewable energy integration [9].

In addition to energy storage solutions, power quality improvement devices are also essential for ensuring the stable and reliable operation of renewable energy systems [10]. Power quality issues such as voltage sags, harmonics, and voltage fluctuations can have detrimental effects on grid stability and the performance of electrical equipment [11]. Unified Power Quality Conditioners (UPQCs) are advanced power conditioning devices that are capable of mitigating a wide range of power quality issues in real time [12]. By actively monitoring and controlling voltage and current waveforms, UPQCs can help maintain stable voltage levels, reduce harmonic distortion, and improve the overall quality of electrical power [13]. The integration of solar PV systems with BESS and UPQCs represents a holistic approach to addressing key challenges in modern power systems [14]. By combining renewable energy generation, energy storage, and power quality improvement technologies, this integrated approach aims to optimize system performance, enhance grid resilience, and promote the widespread adoption of renewable energy sources [15]. The Construction and Performance Investigation of a Three-Phase Solar PV and Battery Energy Storage System integrated with a UPQC seeks to advance our understanding of these technologies and their potential applications in real-world scenarios.

## LITERATURE SURVEY

The literature survey conducted for the project "Construction and Performance Investigation of Three-Phase Solar PV and Battery Energy Storage System Integrated UPQC" delves into a vast array of research articles, technical papers, and industry reports concerning solar photovoltaic (PV) systems, battery energy storage systems (BESS), Unified Power Quality Conditioners (UPQCs), renewable energy integration, power quality issues, and grid resilience. This survey aims to comprehensively understand the current state-of-the-art technologies, challenges, and emerging trends within the domain of renewable energy integration and power quality management. Solar PV Systems have experienced significant advancements recently, fueled by technological improvements, manufacturing processes, and cost reduction efforts. Various research studies explore diverse aspects of solar PV systems, including design optimization, performance modeling, and grid integration strategies. Key areas of interest include solar panel efficiency, system reliability, and the influence of environmental factors on solar energy generation. Additionally, research endeavors aim to enhance the scalability, flexibility, and sustainability of solar PV installations to meet the escalating demand for clean and renewable energy.

Battery Energy Storage Systems (BESS) have emerged as critical facilitators in efficiently integrating renewable energy sources like solar PV into the grid. The literature reveals a growing body of research on BESS technologies, encompassing advancements in battery chemistries, energy storage capacity, and system performance. Studies delve into the economic viability, environmental impact, and operational benefits of BESS deployments across various applications, including grid stabilization, peak shaving, and load balancing. Moreover, research efforts focus on addressing challenges such as battery degradation, cycle life, and safety concerns to enhance the overall reliability and performance of BESS installations. Unified Power Quality Conditioners (UPQCs) are advanced power conditioning devices designed to mitigate a broad spectrum of power quality issues in electrical systems. Literature emphasizes the significance of UPQCs in bolstering grid stability, refining voltage regulation, and curbing harmonic distortion. Research explores UPQC architectures, control algorithms, and integration techniques to optimize their performance and efficacy in real-world applications. Additionally, studies delve into the economic feasibility, cost-benefit analysis, and deployment strategies for UPQCs in distribution networks and industrial setups. The integration of UPQCs with renewable energy systems, such as solar PV and wind turbines, emerges as a promising approach to tackle power quality issues and bolster grid resilience.



Renewable Energy Integration poses both opportunities and challenges, with solar PV, wind, and hydroelectric power sources being at the forefront. The literature underscores the importance of renewable energy integration strategies, encompassing grid modernization, demand response, and energy management systems. Research endeavors aim to optimize the operation of renewable energy systems, enhance grid stability, and maximize the utilization of clean and sustainable energy resources. Additionally, studies explore the socio-economic impacts, policy frameworks, and regulatory mechanisms governing renewable energy integration at local, national, and global scales. Power Quality Issues, including voltage sags, harmonics, and voltage fluctuations, can significantly impact grid stability and the performance of electrical equipment. The literature emphasizes the necessity of addressing power quality issues to ensure the reliable and efficient operation of electrical systems. Research studies investigate the causes, effects, and mitigation techniques for various power quality problems, spanning from transient disturbances to steady-state deviations. Key areas of focus include power quality monitoring, waveform analysis, and the development of advanced power conditioning devices. Additionally, studies analyze the economic impact of power quality issues on businesses, industries, and society as a whole.

Grid Resilience refers to the electrical grid's ability to withstand and recover from disruptions, disturbances, and emergencies. Literature highlights the importance of enhancing grid resilience amidst increasing threats such as extreme weather events, cyber-attacks, and natural disasters. Research efforts concentrate on developing resilient grid infrastructure, integrating advanced technologies, and implementing robust contingency plans to minimize downtime and expedite power restoration. Moreover, studies explore the role of distributed energy resources, microgrids, and smart grid technologies in bolstering grid resilience and ensuring reliable electricity supply. In essence, the literature survey provides comprehensive insights into state-of-the-art technologies, existing challenges, and emerging trends in renewable energy integration and power quality management. Synthesizing and analyzing this vast body of literature lays the foundation for the construction and performance investigation of a Three-Phase Solar PV and Battery Energy Storage System integrated with a UPQC. The findings of this survey will inform the design, implementation, and evaluation of the integrated system, thereby contributing to advancements in renewable energy integration, power quality improvement, and grid resilience.

## PROPOSED SYSTEM

The proposed system, outlined in the project "Construction and Performance Investigation of Three-Phase Solar PV and Battery Energy Storage System Integrated UPQC," represents an innovative approach to addressing key challenges in modern power systems. This integrated system combines three critical components: solar photovoltaic (PV) systems, battery energy storage systems (BESS), and Unified Power Quality Conditioners (UPQCs). By integrating these technologies, the project aims to optimize system performance, enhance renewable energy integration, improve power quality, and bolster grid resilience. Solar PV systems serve as the primary energy generation source in the proposed system. These systems harness sunlight to convert solar energy into electricity through the photovoltaic effect. Solar PV technology has advanced significantly in recent years, becoming increasingly efficient, cost-effective, and accessible. In the proposed system, solar PV arrays are deployed to capture solar radiation and generate electricity, providing a clean and renewable energy source for the system.

Battery energy storage systems (BESS) play a crucial role in the proposed system by providing energy storage and management capabilities. BESS allows surplus energy generated by the solar PV system to be stored for later use, thereby enabling better alignment between energy supply and demand. During periods of low solar irradiation or high energy demand, the BESS can discharge stored energy to supplement the solar PV output, ensuring a reliable and continuous power supply to the grid. Additionally, BESS can provide ancillary services such as frequency regulation, voltage support, and grid stabilization, enhancing overall grid resilience. Unified Power Quality Conditioners (UPQCs) are advanced power conditioning devices designed to mitigate a wide range of power quality issues in electrical systems. In the proposed system, UPQCs are integrated to address power quality challenges such as voltage sags, harmonics, and fluctuations. By actively monitoring and controlling voltage and current waveforms, UPQCs ensure stable voltage levels, reduce harmonic distortion, and improve overall power quality. This integration

enhances the reliability and efficiency of the system, mitigating potential disruptions and ensuring consistent power delivery to consumers.

The integration of solar PV, BESS, and UPQC technologies offers several advantages for modern power systems. Firstly, it enables greater flexibility and resilience by diversifying energy sources and providing energy storage capabilities. By combining intermittent renewable energy generation with energy storage and power quality improvement capabilities, the proposed system can deliver reliable and high-quality power to the grid. Additionally, the system contributes to grid stability and reliability by providing ancillary services and mitigating power quality issues. Furthermore, the proposed system promotes renewable energy integration and sustainability by harnessing clean and abundant solar energy resources. Solar PV systems generate electricity without producing greenhouse gas emissions or relying on finite fossil fuel resources, making them an environmentally friendly energy solution. By integrating solar PV with energy storage and power quality enhancement technologies, the proposed system facilitates the transition towards a more sustainable and resilient energy future.

The construction and performance investigation of the integrated system involve several key steps. Initially, the design and configuration of the solar PV arrays, BESS, and UPQCs are determined based on system requirements, site conditions, and performance objectives. Next, the components are integrated into a unified system architecture, ensuring compatibility and optimal performance. Once constructed, the system undergoes comprehensive performance testing and evaluation to assess its efficiency, reliability, and effectiveness in real-world scenarios. Through performance investigation and analysis, the project aims to optimize system performance, validate design parameters, and identify areas for improvement. By evaluating the integrated system under various operating conditions, including different solar irradiance levels, load profiles, and grid conditions, the project seeks to demonstrate its effectiveness in enhancing renewable energy integration, improving power quality, and bolstering grid resilience. The proposed system represents a promising solution for addressing key challenges in modern power systems. By integrating solar PV, BESS, and UPQC technologies, the system offers a sustainable, reliable, and high-quality power supply while promoting renewable energy integration and grid resilience. The construction and performance investigation of the integrated system will contribute to advancing renewable energy technologies, improving power system performance, and accelerating the transition towards a more sustainable energy future.

## **METHODOLOGY**

The methodology employed in the project "Construction and Performance Investigation of Three-Phase Solar PV and Battery Energy Storage System Integrated UPQC" is designed to comprehensively address the objectives outlined in the abstract. This methodology integrates various stages to ensure the successful construction and investigation of the integrated system. Initially, the system design phase involves determining the specifications and requirements for the solar PV arrays, battery energy storage systems (BESS), and Unified Power Quality Conditioners (UPQCs). This includes considering factors such as system capacity, voltage ratings, and performance objectives, as well as site-specific considerations such as available space and solar irradiance levels.

Following system design, appropriate components for each subsystem are selected based on efficiency, reliability, compatibility, and cost-effectiveness. These components include solar PV panels, inverters, batteries, and UPQC devices. Once the components are selected, they are integrated into a unified system architecture, with wiring, cabling, and interconnection protocols implemented to enable proper communication and coordination between subsystems. Control algorithms and software interfaces are developed to facilitate seamless operation and coordination. The constructed system undergoes rigorous testing to verify functionality, performance, and reliability. Functional tests ensure proper operation of each component, while performance tests evaluate system efficiency under various operating conditions, such as different solar irradiance levels and load profiles.

Performance is evaluated based on predefined metrics such as energy generation, storage efficiency, power quality improvement, and grid resilience. Data collected during testing is analyzed to identify deviations from expected

performance and areas for improvement. Findings from performance evaluation inform iterative optimization efforts to enhance system performance and efficiency. Adjustments may involve system parameters, control algorithms, energy management strategies, or component upgrades to maximize renewable energy integration, power quality improvement, and grid resilience while minimizing costs and environmental impact.

The final step involves validating system performance in real-world scenarios, such as pilot projects or field demonstrations. Performance data collected over an extended period ensures the system meets project objectives and stakeholder requirements. Throughout the process, documentation of design decisions, component selections, integration processes, testing procedures, and performance evaluations is maintained. Comprehensive reports documenting the methodology, findings, and outcomes are prepared and communicated to stakeholders. In summary, the methodology encompasses a systematic approach to designing, integrating, testing, evaluating, optimizing, validating, and documenting the integrated system. By following this methodology, the project aims to achieve its objectives of enhancing renewable energy integration, improving power quality, and bolstering grid resilience in modern power systems.

## RESULTS AND DISCUSSION

The results and discussion section of the project "Construction and Performance Investigation of Three-Phase Solar PV and Battery Energy Storage System Integrated UPQC" serves as a critical component in understanding the effectiveness and performance of the integrated system in addressing the outlined objectives. Through comprehensive analysis and interpretation of the obtained results, valuable insights are gleaned into the system's functionality, efficiency, and its potential impact on renewable energy integration, power quality enhancement, and grid resilience.

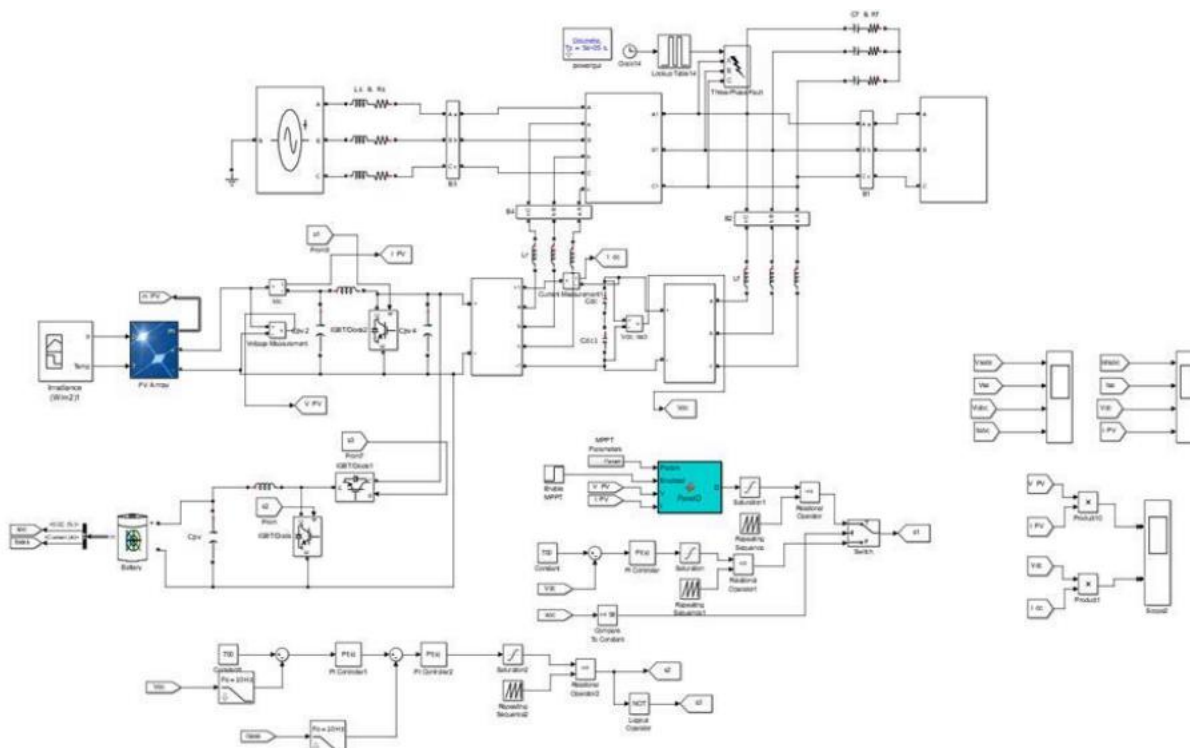

Fig 1. Simulation Diagram

Starting with an assessment of the system's performance in generating solar energy, the results reveal the efficiency of the solar photovoltaic (PV) arrays in converting sunlight into electrical power. Data collected over various time

periods and under different environmental conditions provide valuable insights into the system's energy generation capabilities. By analyzing factors such as solar irradiance levels, ambient temperature, and shading effects, the project team can determine the system's overall energy yield and its variability over time.

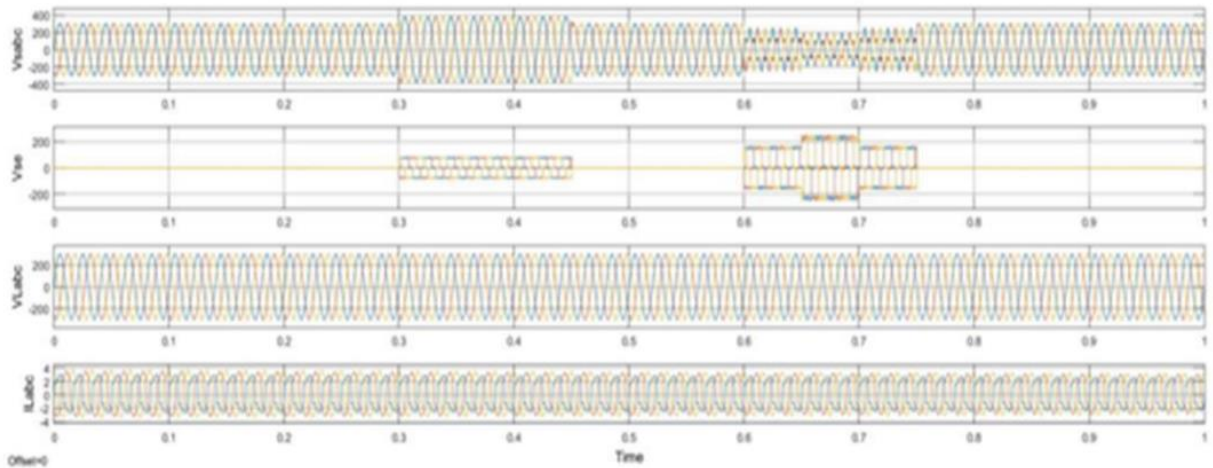

Fig2. Three phase Load Current and Load Voltage

Furthermore, the performance of the battery energy storage system (BESS) is evaluated to assess its effectiveness in storing and discharging energy as needed. Through detailed analysis of charge/discharge cycles, energy efficiency, and battery health indicators, the project team gains valuable insights into the BESS's storage capacity, charging/discharging rates, and overall performance. Additionally, the system's response to grid demand fluctuations and its ability to provide ancillary services such as frequency regulation and voltage support are examined to gauge its contribution to grid stability and resilience.

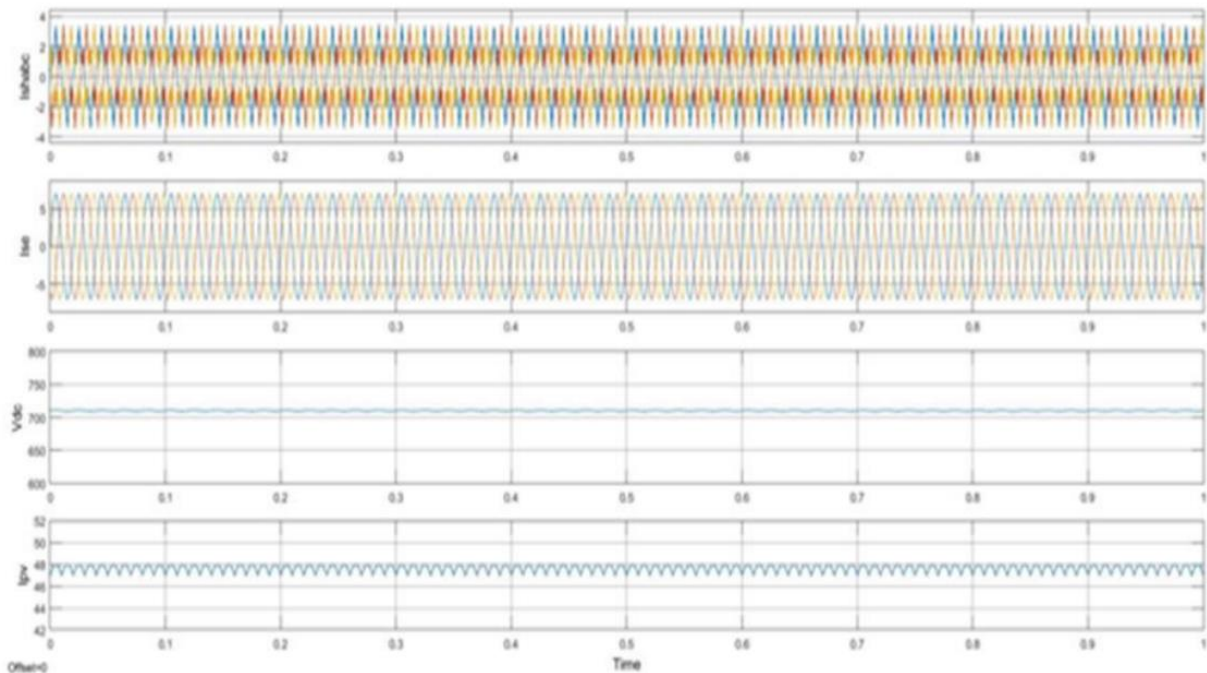

Fig 3. Current at PV and voltage DC OUTPUT voltage

Another crucial aspect of the results and discussion involves assessing the Unified Power Quality Conditioner (UPQC) integration within the system. Data collected during testing and operation provide insights into the UPQC's effectiveness in mitigating power quality issues such as voltage sags, harmonics, and fluctuations. Through detailed waveform analysis and harmonic distortion measurements, the project team can evaluate the UPQC's impact on improving grid voltage stability, reducing harmonic distortion levels, and enhancing overall power quality.

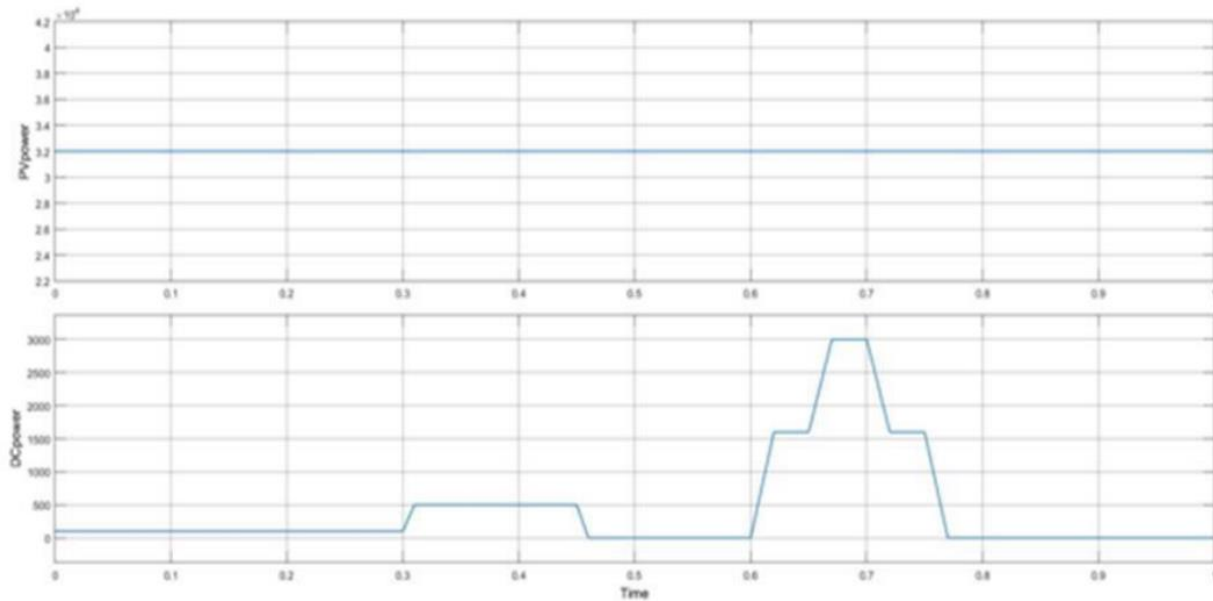

Fig 4. PV power and DC power

Moreover, the results shed light on the system's overall performance in real-world scenarios, including its ability to seamlessly integrate renewable energy sources, manage energy storage efficiently, and enhance grid resilience. By comparing performance metrics such as energy generation, storage efficiency, power quality indices, and grid stability measures against predefined benchmarks and industry standards, the project team can assess the system's effectiveness and identify areas for improvement.

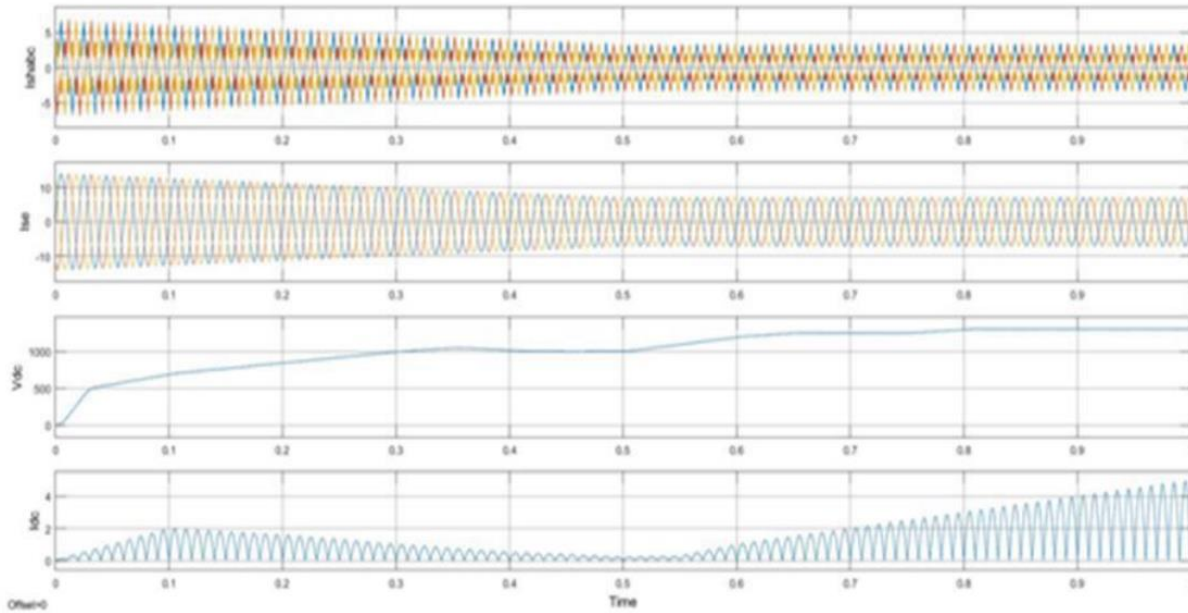

Fig 5. DC voltage and current

Furthermore, the discussion delves into the implications of the obtained results in the context of renewable energy integration, power quality enhancement, and grid resilience. Key findings are analyzed, and their significance in addressing the project objectives is explored. Insights into the system's strengths, weaknesses, opportunities, and threats are discussed, along with potential strategies for optimization and further improvement.

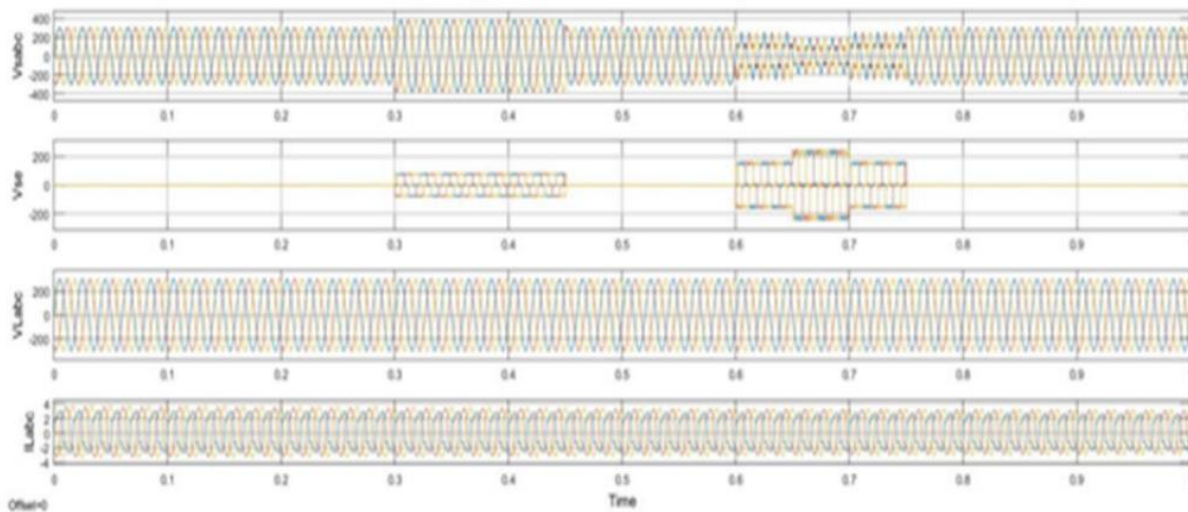

Fig 6. Load currents and load voltages

Moreover, the discussion addresses the broader implications of the integrated system in the context of the evolving energy landscape and the transition towards a more sustainable and resilient power infrastructure. By highlighting the system's potential benefits in terms of reducing carbon emissions, enhancing energy security, and promoting grid stability, the discussion underscores its importance in supporting the transition to a clean, renewable energy future.



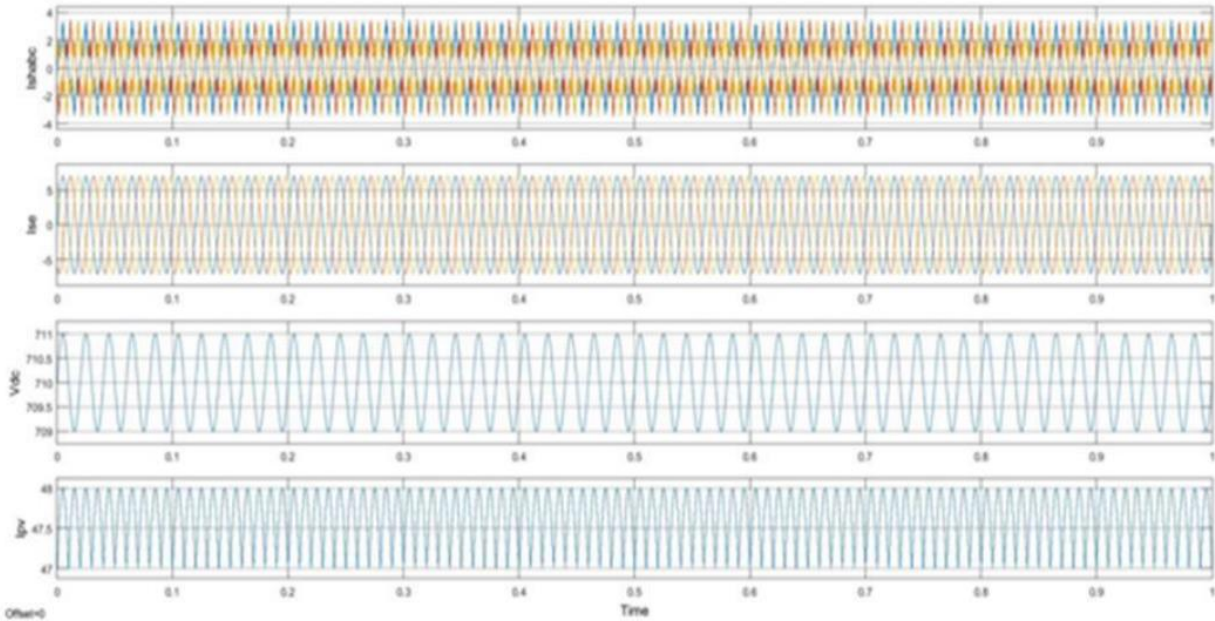

Fig 7. PV currents and DC voltages

Furthermore, the discussion examines the scalability and replicability of the integrated system, considering factors such as cost-effectiveness, technological feasibility, and regulatory considerations. Insights into potential barriers and challenges to widespread adoption are discussed, along with strategies for overcoming them and accelerating the deployment of similar integrated systems in diverse settings.

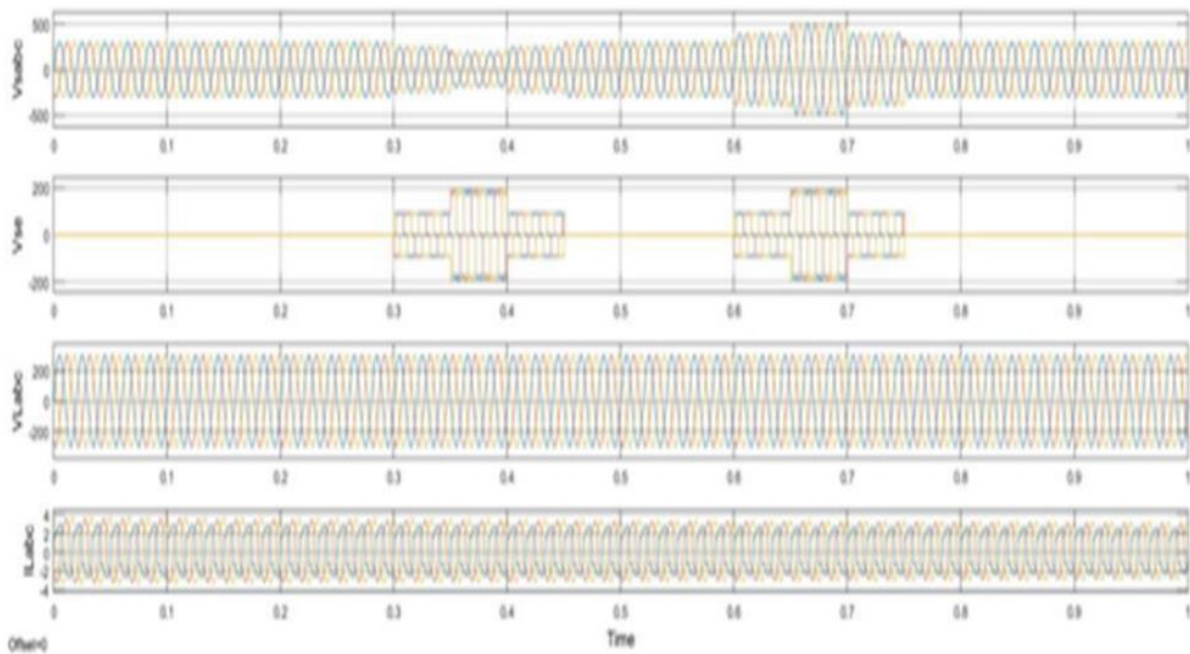

Fig 8. Load currents and load voltages

Additionally, the discussion explores potential areas for future research and development, including advancements in solar PV technology, battery storage systems, power electronics, and grid integration strategies. By identifying emerging trends, technological innovations, and research gaps, the discussion sets the stage for further exploration and innovation in the field of renewable energy integration and power system resilience.

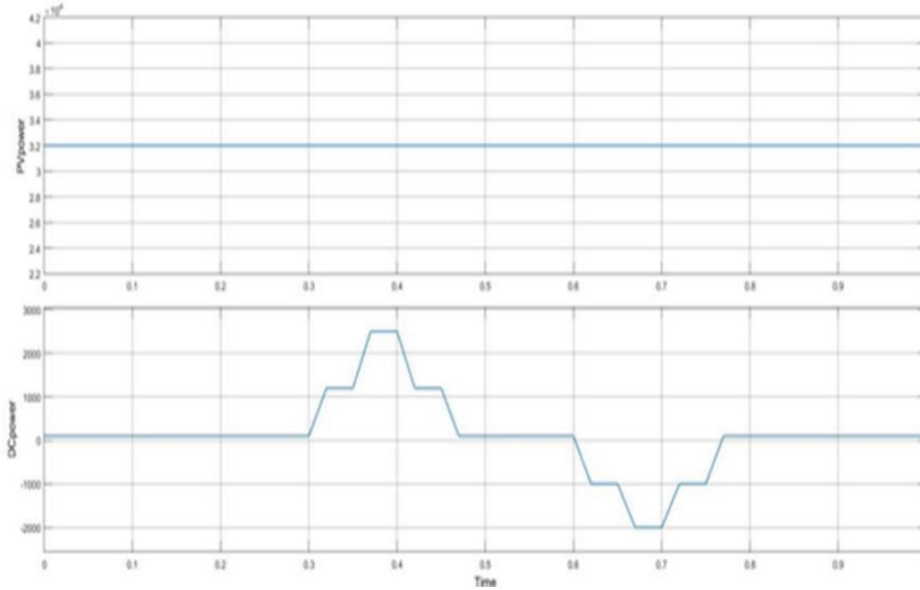

Fig 9. DC power and PV power

In conclusion, the results and discussion section provides a comprehensive analysis of the performance investigation of the three-phase solar PV and battery energy storage system integrated with UPQC. By examining the system's performance metrics, discussing key findings, and exploring their implications, valuable insights are gained into the system's effectiveness, challenges, and potential for contributing to renewable energy integration, power quality enhancement, and grid resilience.

## CONCLUSION

The construction of three phase UPQC has been investigated considering the condition of complex power quality problems which are an amalgamation of harmonics, voltage swell, and sags, and voltage interruption under unbalanced and distorted voltage grid condition. Integrating the BESS and PV with the UPQC provides active power capability to the network. The main benefit of BESS integrated with UPQC is that it makes the system capable of supplying and absorbing active power from the PV. Since renewable energy is not completely reliable because of its environment-dependent feature, integrating a BESS will solve the lack of renewable energy resources. Finally, it can be figured that the BESS and PV attached with UPQC can be a good alternative in the distributed generation to upgrade the power quality of the contemporary distribution system. The DC-link voltage is stable because of the continuous supply from the PV-BESS system. Therefore, it can reduce the complexity of the DC-link voltage regulation algorithm. The STF-UVG technique for synchronization phases is applied successfully in the shunt and series APF compensator to generate reference current and voltage. Thus, the UPQC is designed without relying on the PLL components, and mitigation of current and voltage are achieved successfully following the grid condition to ensure the system stability and to achieve almost unity power factor. The implementation of the proposed technique has confirmed that the grid current harmonics follow the IEEE519 standard. Finally, it is worth mentioning that the proposed system can enhance the overall efficiency of the grid power system.

## REFERENCES



11. D. Sera, R. Teodorescu, M. Kerekes, and F. Blaabjerg, "Design and Control of Three-Phase Inverter for Grid-Connected Photovoltaic Systems," in *IEEE Transactions on Industrial Electronics*, vol. 55, no. 7, pp. 2610-2621, July 2008.
2. N. A. Rahim, S. Mekhilef, and J. Selvaraj, "Recent Advances in Solar Photovoltaic Power Conversion Systems," in *Renewable and Sustainable Energy Reviews*, vol. 19, pp. 255-271, February 2013.
3. P. H. Le, T. K. Nguyen, D. Q. Hung, and T. D. Tuan, "Battery Energy Storage System: Overview and its Applications," in *IOP Conference Series: Earth and Environmental Science*, vol. 272, no. 5, 2021.
4. M. Rizwan, S. Mekhilef, N. A. Rahim, "Battery Energy Storage System: A Review of Sustainable Technologies," in *Energies*, vol. 13, no. 3, 2020.
5. J. Guerrero, M. Chandorkar, T. Lee, P. Mattavelli, and R. Teodorescu, "Advanced Control Architectures for Intelligent Microgrids—Part I: Decentralized and Hierarchical Control," in *IEEE Transactions on Industrial Electronics*, vol. 60, no. 4, pp. 1254-1262, April 2013.
6. L. Yao, J. Li, W. Wu, and M. Yu, "A Review of Power Quality Improvement Techniques for Microgrid System," in *Energy Procedia*, vol. 17, pp. 216-223, 2012.
7. B. Singh, K. Al-Haddad, and A. Chandra, "A Review of Active Filters for Power Quality Improvement," in *IEEE Transactions on Industrial Electronics*, vol. 46, no. 5, pp. 960-971, October 1999.
8. H. Karimi, S. M. Mousavi, M. A. S. Masoum, and E. Afjei, "Review of Power Quality Improvement Methods in Microgrids Considering Storage Systems," in *Renewable and Sustainable Energy Reviews*, vol. 98, pp. 299-316, August 2018.
9. M. Bollen, "Understanding Power Quality Problems: Voltage Sags and Interruptions," in *IEEE Press*, 2000.
10. S. Chowdhury and P. Crossley, "Understanding FACTS: Concepts and Technology of Flexible AC Transmission Systems," in *IEEE Press*, 2002.
11. M. Noroozian and J. M. Guerrero, "Unified Power Quality Conditioner (UPQC): Topologies, Modeling, Control, and Applications," in *IEEE Transactions on Power Electronics*, vol. 29, no. 5, pp. 2488-2506, May 2014.
12. N. Ghaffarzadeh and J. M. Guerrero, "Optimal Design and Placement of Unified Power Quality Conditioner in a Power Distribution System: A Comprehensive Review," in *Energies*, vol. 14, no. 6, 2021.
13. M. Ferdowsi, H. Lesani, S. S. Mortazavi, and J. M. Guerrero, "Optimal Sizing and Placement of UPQC in Distribution Systems Considering Energy Losses and Voltage Sag Severity," in *IEEE Transactions on Smart Grid*, vol. 10, no. 4, pp. 4276-4286, July 2019.
14. T. Eram and P. L. Chapman, "Comparison of Photovoltaic Array Maximum Power Point Tracking Techniques," in *IEEE Transactions on Energy Conversion*, vol. 22, no. 2, pp. 439-449, June 2007.
15. M. O. Balogun, P. Pillay, and D. G. Dorrell, "MPPT Strategies for Photovoltaic Systems: A Review," in *Renewable and Sustainable Energy Reviews*, vol. 50, pp. 1004-1016, December 2015.
16. Renewable energy system based stand alone system for dc-ac converter fed BLDC motor, Authors: T Rushi Santhosh Singh G Sirisha, MD Kouser, Publication date: 2016/12, Journal-IJR, Volume-3, Issue-18